

# TANKLESS GAS WATER HEATER

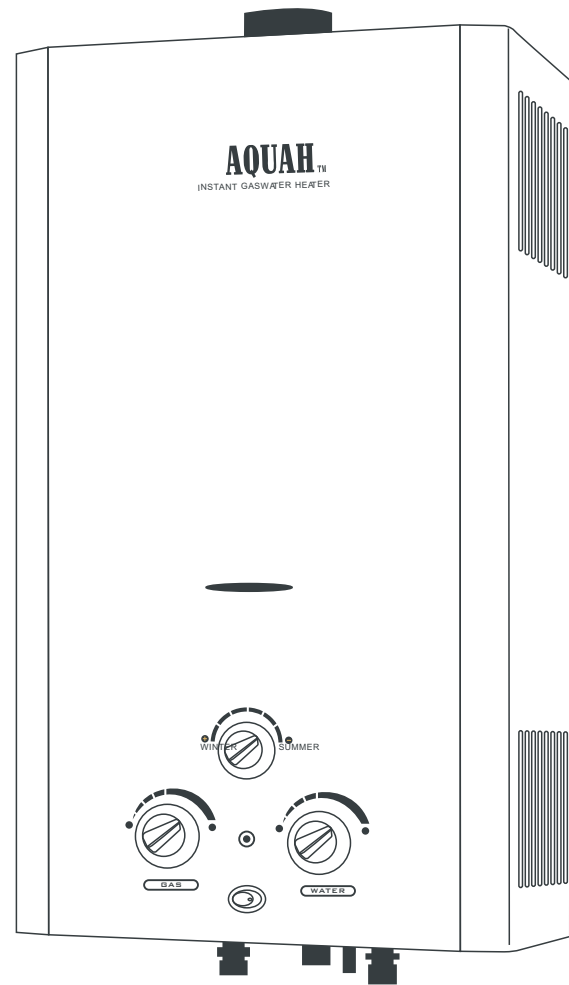

## Flue Duct Type Suitable For Heating Potable Water Only



The exterior of the gas water heater shown in this manual is for reference only. The exterior of the actual gas water heater you purchased may vary from what's shown in this manual.

### What to do if you smell gas

- Open windows;
- Close gas valve;
- Do not try to light any appliance;
- Do not touch any electrical switch;
- Do not use any phone in your building;
- Immediately call your gas supplier from a neighbor's phone. Follow the gas supplier's instructions;
- If you cannot reach your gas supplier, call the fire department;
- Installation and service must be performed by a qualified installer, service agency or the gas supplier.

**Warning:** if the information in this manual is not followed exactly, a fire or explosion may result causing property damage, personal injury or death. Do not store or use gasoline or other flammable vapor and liquids in the vicinity of this or any other appliance.

Improper installation, adjustment, alteration, service or maintenance can cause injury or property damage. Refer to this manual. For assistance or additional information consult a qualified installer, service agency or the gas supplier.

In the Commonwealth of Massachusetts the installation must be performed by a licensed plumber or gas fitter.

Upon completion of the installation, these instructions should be handed to the user of the appliance for future reference.

## Index

1	Warning	1
2	Appliance details	2
2.1	Gas water heater specifications	2
2.2	Unpacking the gas water heater	2
2.3	General rules to follow for safe operation	2
2.4	Dimensions and installation clearances	3
3	Installation instructions	4
3.1	Introduction	4
3.2	Proper location for installing your heater	4
3.3	Heater placement and clearances	4
3.4	Mounting heater	4
3.5	Combustion air requirements	6
3.6	Venting	6
3.7	Gas piping & connections	8
4	Operation instructions	10
4.1	For your safety read before operating your water heater	10
4.2	Lighting instructions	10
4.3	To turn off appliance	10
4.4	Setting the temperature	10
4.5	Power adjustment	11
4.6	Winter/Summer options	11
4.7	Purge the appliance	11
5	Maintenance and service	11
5.1	Maintenance intervals	11
5.2	Ignition and sensor pins	11
5.3	Main burners	12
5.4	Vent assembly	12
5.5	Mineral scale build-up	12
6	Troubleshooting	12
6.1	Introduction	12
6.2	No spark at ignition pin with water flow	12
6.3	Spark appears when hot water is turned on, but burners will not ignite	13
6.4	Main burners go out during hot water use	13
6.5	Hot water temperature fluctuates at tap	13
6.6	Water is too hot	14
6.7	Water is not hot enough	14
6.8	Low hot water pressure	14
6.9	Noise when heater is running	15
6.10	Burners do not burn cleanly, yellow flames when operating	15
7	Protecting the environment	15
8	Interior components, diagram, and parts list	16
8.1	Interior components	16
8.2	Components diagram	17
8.3	Parts list	18
9	Warranty	18

## 1) Warning



**Warning:** The heater must be isolated from the gas supply piping system during any pressure testing of that system at test pressure equal to or more than 0.5 psi (3447Pa)



**Caution:** Any changes or modifications not expressly approved by the party responsible for compliance could void the users' authority to operate the equipment.

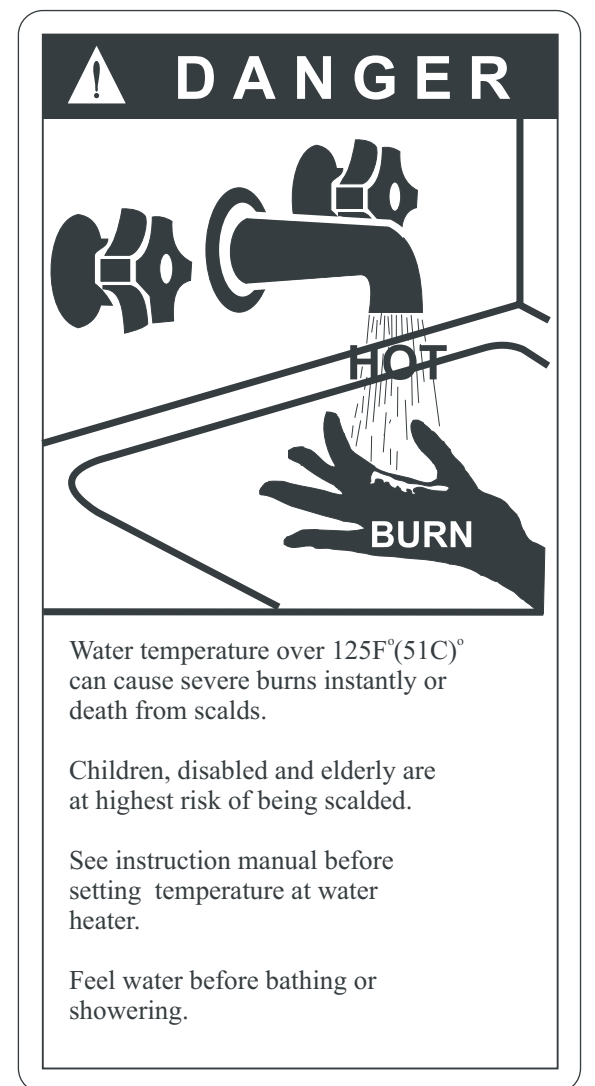

Fig. 1.1



**Warning:** Gasoline, as well as other flammable materials and liquids (adhesives, solvents, paint thinners etc.), and the vapor they produce are extremely dangerous. DO NOT handle, use or store gasoline or other flammable or combustible materials anywhere near or in the vicinity of a water heater or any other appliance. Be sure to read and follow the labels on the water heater, as well as the warnings printed in this manual. Failure to do so can result in property damage, bodily injury or death.

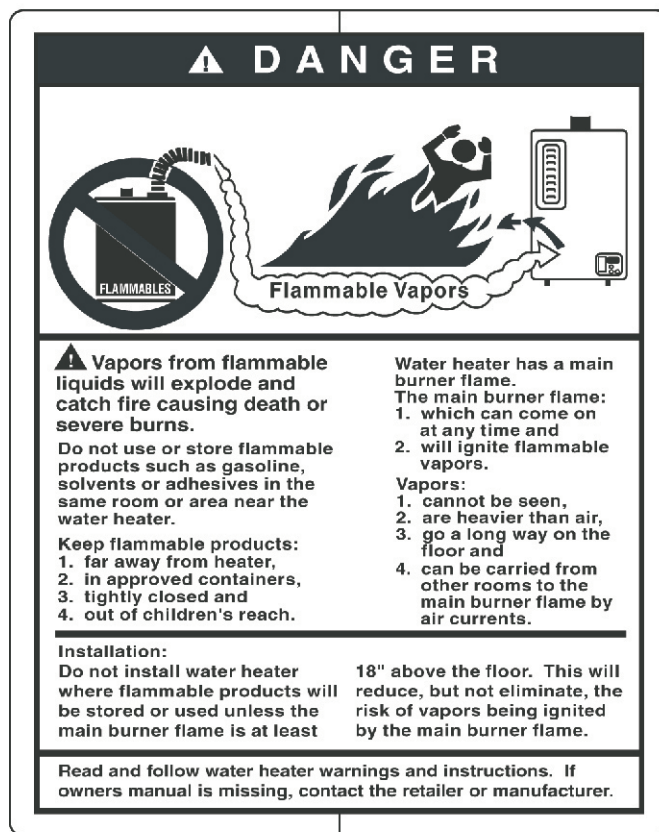

Fig. 1.2

## 2) Appliance details

### 2.1 Gas water heaters specifications

- Heat efficiency: >85%
- Gas Requirement
- Gas connection (inches)-G1/2
- Inlet gas pressure under maximum operation
- Propane: 11 water column (2800Pa)
- Natural Gas: 8 water column (2000Pa)
- Connections: Bottom of the heater
- Gas types: Natural Gas or LP Gas

- Venting
- Natural Draft
- Minimum height : 6 feet (15.5cm) with no elbows
- Water
- Hot water connection (inches)- G1/2
- Cold water connection (inches)- G1/2
- Water valve material: Brass
- Minimum recommended startup water pressure: 5 PSI (35kPa)

### 2.2 Unpacking the gas water heater

This heater is packed securely. Before installing the unit, be certain you have the correct heater for your type of Gas - Propane or Natural Gas.

Model	Capacity	Size A (mm)	Size B (mm)	Size C (mm)	Size D (mm)	Size E (mm)
JSD10-K	5L	425	290	118	90	25
JSD12-K	6L	440	300	118	90	25
JSD14-K	7L	520	320	148	90	25
JSD16-K	8L	550	328	178	110	25
JSD20-K	10L	610	350	168	110	25
JSD24-K	12L	610	350	168	110	2
JSD32-K	16L	710	420	210	135	25

Fig. 2.1 Rating plate

The box includes:  
Gas water heater  
Mounting screws  
Installation manual

Do not lose this manual, there is a charge for a replacement.



**Warning:**

The gas water heater is not designed for: installation in bathroom, bedroom, or other occupied rooms normally kept closed, heating or other recirculating pumps applications, solar preheat backup or high temperature booster use.

### 2.3 General rules to follow for safe operation

- You should follow these instructions when you install your heater. In the United States: The installation must confirm with local codes or, in the absence of local codes, the National Fuel Gas Code ANSI Z223.1/NFPA54.

- Carefully plan where you install the heater. Proper clearances must be followed.
- The appliance must be isolated from the gas supply piping system by closing its individual manual gas shut off valve ( not supplied with heater ) during any pressure testing at pressures in excess of 0.5psi (3.5kPa)
- Keep water heater area clear and free from combustibles and flammable liquids. Do not locate the heater over any material which might burn.
- Correct gas pressure is critical for the optimum operation of this heater. Gas piping must be sized to provide the required pressure at the maximum output of the heater, while all the other gas appliances are in operation. Check with your local gas supplier.
- Should overheating occur or the gas supply fail to shut off, turn off the gas supply at the manual gas shut off valve, on the gas line. Note: manual gas shut off valve is not supplied with the heater
- Do not use this appliance if any part has been underwater. Immediately call a qualified service technician to inspect the appliance and to replace any part of the control system and any gas control which has been underwater



We are constantly improving our products, therefore specifications are subject to change without prior notice.

### 2.4 Dimensions and installation clearances

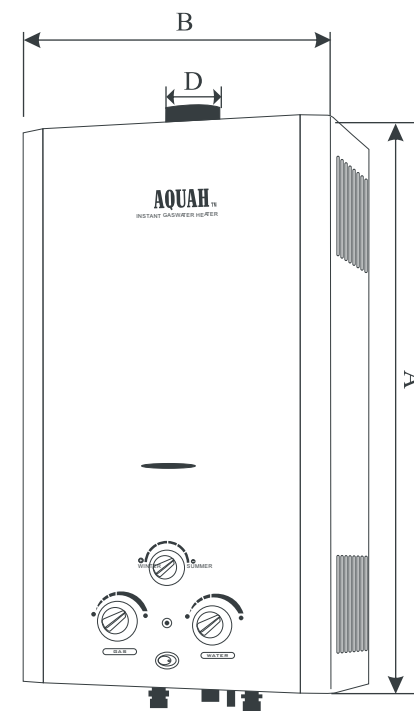

Fig. 2.2

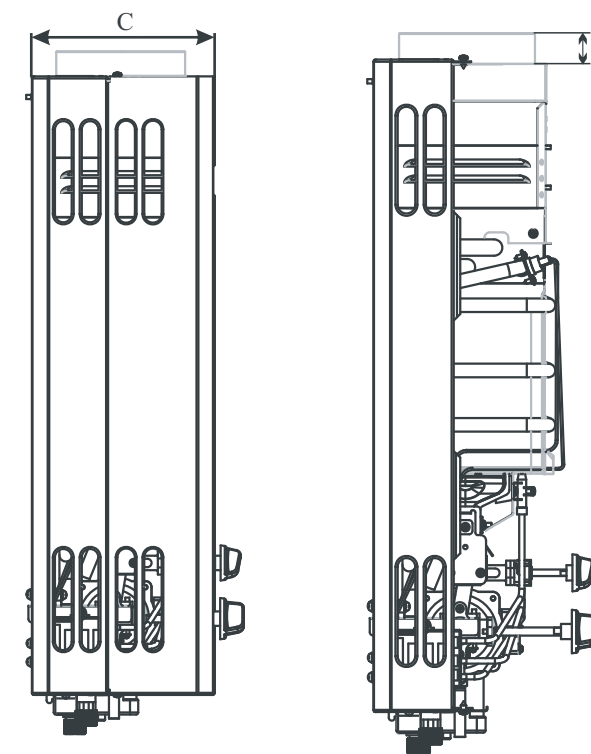

Fig. 2.3

Fig. 2.4

The following two tables (2.1 & 2.2) show the same dimensions but in different units

Model	Capacity	Size A (mm)	Size B (mm)	Size C (mm)	Size D (mm)	Size E (mm)
JSD10-K	5L	425	290	118	90	25
JSD12-K	6L	440	300	118	90	25
JSD14-K	7L	520	320	148	90	25
JSD16-K	8L	550	328	178	110	25
JSD20-K	10L	610	350	168	110	25
JSD24-K	12L	610	350	168	110	2
JSD32-K	16L	710	420	210	135	25

Table 2.1

Model	Rated input heat (Btu)	Size A (Inch)	Size B (Inch)	Size C (Inch)	Size D (Inch)	Size E (Inch)
JSD10-K	34100	16.7	11.4	4.6	3.5	1.0
JSD12-K	40900	17.3	11.8	4.6	3.5	1.0
JSD14-K	47000	20.5	12.6	5.8	3.5	1.0
JSD16-K	54500	21.7	12.9	7.0	4.3	1.0
JSD20-K	68200	24.0	13.8	6.6	4.3	1.0
JSD24-K	81800	24.0	13.8	6.6	4.3	1.0
JSD32-K	109000	28.0	16.5	8.3	5.3	1.0

Table 2.2

Minimum clearance required for installation

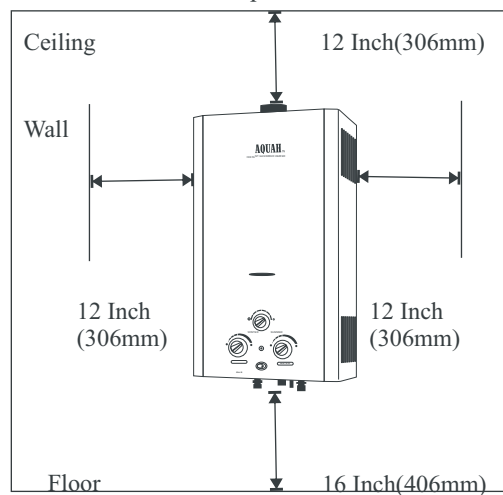

Fig. 2.5

Warning: Flammable materials, gasoline, pressurized containers, or any other items or articles that are potential fire hazards must NOT be placed on or adjacent to the heater. The appliance area must be kept free of all combustible materials, gasoline and other flammable vapors and liquids.

**Warning:** The heater must be isolated from the gas supply piping system during any pressure testing of that system at test pressures equal to or more than 0.5 psi (3.4kPa)

**Warning:** Place the heater in a location where water leaks will do NO DAMAGE to adjacent areas.

### 3). Installation instructions

#### 3.1 Introduction

Please follow those instructions. Failure to follow instructions may result in:

- Damage or injury.
- Improper operation
- Loss of warranty

If you are unable to perform the tasks required to install this heater properly, please contact a locally licensed plumber or gas technician. Please contact retailer with any questions.

#### 3.2 Proper location for installing your heater

Carefully select the location of the water heater. For your safety and for proper heater operation, you must provide combustion air to the heater and a proper exhaust vent system.

Follow the guidelines below:

1. Locate the heater where venting, gas and plumbing connection are feasible and convenient.
2. The hot water lines should be kept short to save energy. Centrally locating the water heater is the best. It is always advisable to have hot water lines insulated.

**Warning:** The water in this water heater is cold and always remains cold except for the times that hot water is being used. DO NOT INSTALL IN AN AREA WHERE IT COULD FREEZE. Drain the heater entirely if freezing temperatures are anticipated in area where heater is installed. See chapter 4.7 for draining instructions. To prevent any freeze damage, introduce short bursts of compressed air (20-40psi/0.14-0.28mPa) through these connection to remove the residual water in the horizontal pipes and water valve

#### 3.3 Heater placement and clearances

The water heater is designed for installation on a non-combustible wall (see 3.4 mounting installation) provided the floor below the heater is non-combustible.

#### 3.4 Mounting heater

The gas water heater is designed for mounting on a wall

**Warning:** Do not install this appliance on a carpeted or wood paneled wall

The heater must be mounted on a wall using appropriate anchoring materials.

3.4.1 The following drawings show the steps of mounting the heater on the concrete wall.

A. Drill holes in the wall first. Mounting Type A and mounting Type B show different mounting types for different gas water heater models, verify your gas water heater model before you drill the holes. B. There are two types of holes, use 0.31 inch (8mm) auger for hole A, 0.24 inch (6mm) auger for hole B.

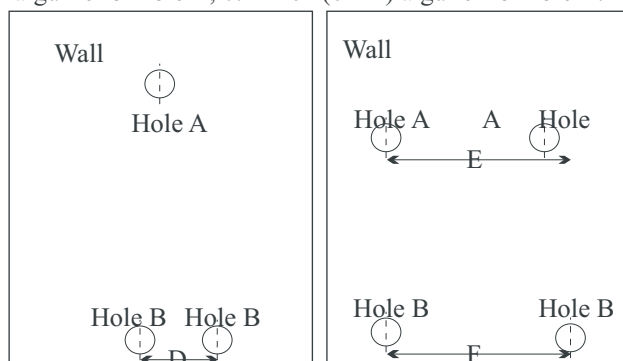

Mounting Type A

Mounting Type B

Fig 3.4.1.1

C. Drive the expansion bolt (metal) into Hole A, drive expansion plug (plastic) into Hole B.

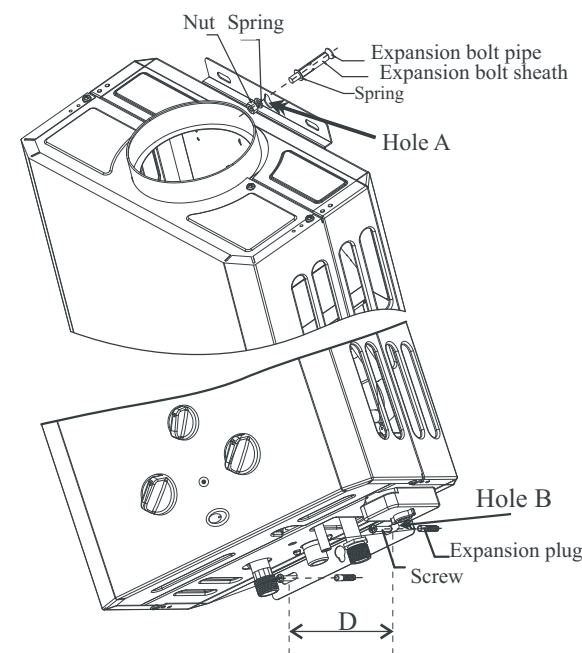

Fig. 3.4.1

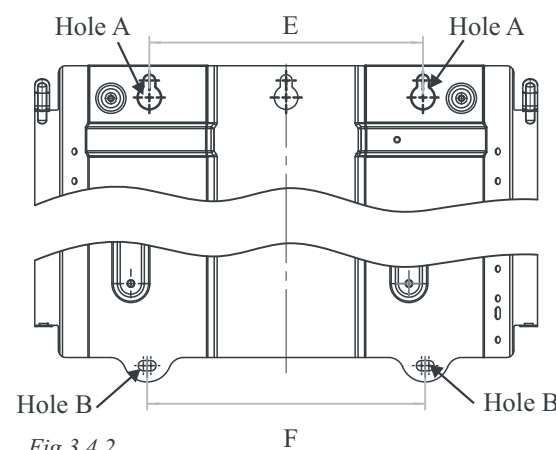

Fig 3.4.2

D. Fig. 3.4.1 shows the mounting Type A, the distance D is as follows:

Model	Capacity	Rated heat input BTU	Distance D mm	Distance D Inch
JSD10-K	5L	34100	160	6.3
JSD12-K	6L	40900	160	6.3
JSD14-K	7L	47000	160	6.3
JSD16-K	8L	54500	167	6.6
JSD20-K	10L	68200	190	7.5
JSD24-K	12L	81800	190	7.5
JSD32-K	16L	109000	263	10.4

Table 3.4.1

E. Fig. 3.4.2 shows the mounting Type B, the distance E and distance F are as follows:

Model	Capacity	Rated heat input BTU	Distance E mm	Distance E Inch	Distance F mm	Distance F Inch
JSD10-K	5L	34100	157	6.2	160	6.3
JSD12-K	6L	47000	157	6.2	160	6.3
JSD14-K	7L	68200	165	6.5	160	6.3
JSD16-K	8L	68200	165	6.5	167	6.6
JSD20-K	10L	81800	185	7.3	190	7.5
JSD24-K	12L	88700	185	7.3	190	7.5
JSD32-K	16L	109000	250	9.8	263	10.4

Table 3.4.2

3.4.2 The following drawings show the steps of mounting the heater on the wood stud wall.

**Warning:** Never mount the gas water heater on combustible wood studs/blockings or plywood boards directly. Always place at least two layers of 5/8" fire rated gypsum boards between the gas water heater and the combustible wood structural framing/support for the heater. The fire rated gypsum boards should be extended minimum 10" beyond the heater's width and height in both directions.

A. It is recommended that supporting boards or wood blockings be attached across a pair of studs; then fasten two layers of 5/8" fire rated gypsum boards onto the supporting boards/wood blockings.

B. Secure two screws on the supporting boards/wood blockings, penetrating through the fire rated gypsum boards. Do not tighten them. Verify the mounting type of your gas heater first. For Mounting Type A, the distance between the screws is shown as "Size D" on table 3.4.1; for Mounting Type B, the distance between the screws is shown as "Size E" and "Size F" on Table 3.4.2. C. Hang heater on the screws, and tighten the screws. See Figs. 3.4.1 and 3.4.2. Please note that the fire rated gypsum boards are not shown on the above figures for graphic clarity purposes.

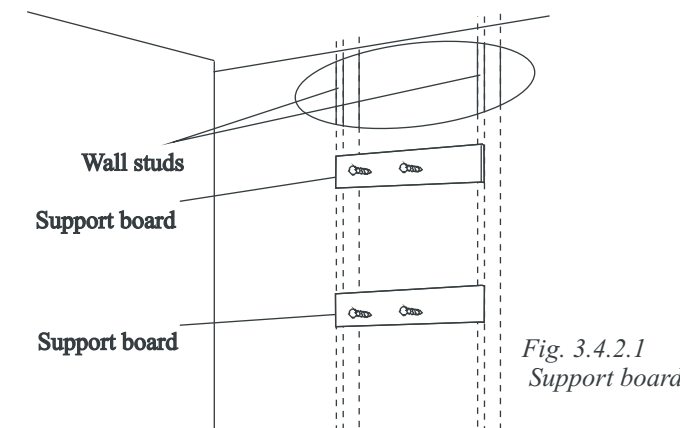

Fig. 3.4.2.1 Support board

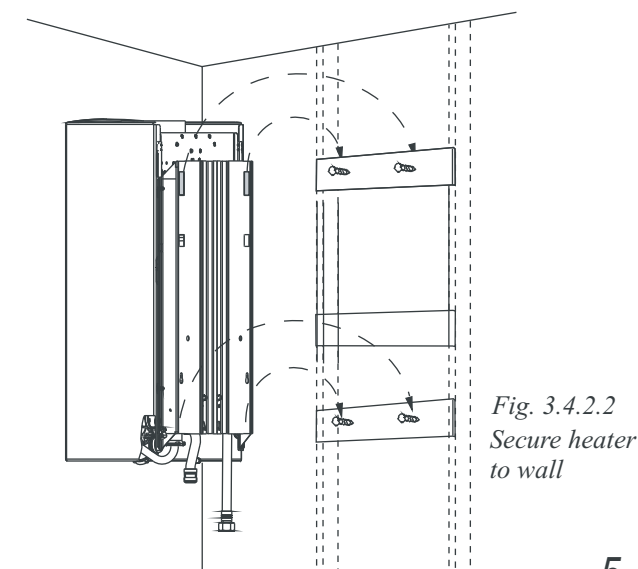

Fig. 3.4.2.2 Secure heater to wall

### 3.5 Combustion air requirements

The gas water heater holds cold water in its copper heat exchanger and water valve when not in use. Because of this, any cold air that comes down through the units vent pipe is capable of freezing these components. This installation manual specifies the minimum vertical vent pipe and the amount of combustion air required for this unit. When all requirements are followed, the unit will operate properly and safely. However, there may still be a risk of freezing due to negative draft if all the combustion appliances in the area are not being supplied with a sufficient amount of make-up air. A wood stove or furnace can rob the makeup air in the gas water heaters vent pipe, leaving the cold infiltrating air capable of freezing the cold water in the heat exchanger of water heater. Supplying more combustion air for all combustion appliances is the solution. Follow the instruction on venting and checking adequacy of make up air. AHVAC specialist should be used to design solutions for providing more make up air if necessary. Observe the following instructions concerning combustion air.

Appliances located in unconfined spaces:

a) An unconfined space is one whose volume is greater than 50 cubic feet (1.4 cubic meter) per 1000 Btu (0.3Kw) per hour of the combined rating of all appliances installed in the space.

For specified space requirements for different capacities, see tables 3.1 and 3.2

B) Installations in structures that have been tightly constructed (air infiltration rate of 0.40 ACH or less) must be provided for combustion air per the National Fuel Gas Code. Consult a HVAC specialist if your air infiltration rate is questionable.

Appliances located in confined spaces:

The confined space must be provided with two permanent openings, one commencing within 12 inches (30.5cm) of the top and one commencing within 12 inches (30.5cm) of the bottom of the enclosure. Each opening must have a minimum free area of one square inch (6.5 square cm) per:

1000Btu (0.3Kw)/hr if all air is taken from inside the building.

2000Btu (0.58Kw)/hr if all air is taken from the outside by horizontal ducts.

4000Btu (1.17Kw)/hr if all air is taken from the outside by direct openings or vertical ducts.

Or the confined space must be provided with one permanent opening or duct that is within 12 inches of the ceiling of the enclosure. This opening must have a minimum free area of one square inch (6.5 square cm) per:

3000Btu (0.87Kw)/hr if all air is taken from the outside by a direct opening or vertical duct.

Louvers, grills and screens have a blocking effect. If the effective free area is not known, increase the sizes of your opening by 400% if your louvers are wood and by 135% if your louvers are metal. Refer to the National Fuel Gas Code for complete information. In buildings of tight construction all air should be taken from outside.

The following two tables (3.1 & 3.2) show the space required for different heat input, the contents on both tables are the same but in different units.

Rated Input Btu	Cubic feet indoor volume	Squre feet indoor area with 8 ft ceiling	Squre feet indoor area with 10ft ceiling	Square In.of Free Area of One of the 2 Pass-Thru Grilles	Square In.of Free Area of Opening /duct to the Outside
17060	1138	143	114	19	8
20472	1365	171	137	21	11
23884	1593	200	160	24	12
27296	1820	228	182	28	14
34120	2275	285	228	35	18
40944	2729	342	273	41	21
44356	2958	370	296	45	23
54592	3640	455	364	55	28
68240	4550	569	455	69	35

Table 3.1

Rated Input Kw	Cubic meter indoor volume	Squre meter indoor area with 2.44m ceiling	Squre meter indoor area with 3.1m ceiling	Square cm.of Free Area of One of the 2 Pass-Thru Grilles	Square cm.of Free Area of Opening / duct to the Outside
10	32.2	15.9	12.7	211	88
12	38.6	19	15.2	233	122
14	45.1	22.2	17.8	266	133
16	51.5	25.3	20.2	311	155
20	64.4	31.8	25.3	388	200
24	77.2	38	30.3	455	233
26	83.7	41.1	32.9	499	255
32	103	50.6	40.4	611	311
40	128.8	63.2	50.6	766	388

Table 3.2

### 3.6 Venting



**Danger:** Do not reduce the vent pipe size. Do not put an elbow directly on top of heater. Failure to follow venting requirements may result in dangerous exhaust gases to enter living space.

The minimum vent pipe diameter: see "Size D" on tables 2.1 & 2.2. Minimum vertical vent height: 6feet (182.9cm) with no elbows. Establish 18inch (45.5cm) rise before any elbow  
The heater must be vented to the outside following all local ordinances and specifications for installing a gas appliance vent or chimney. The heater must be located as close as practicable to a vertically rising chimney or vent that has a listed vent cap at its termination point. The venting system must be designed and constructed so as to develop a positive flow adequate to remove flue gases to the outdoors. Consult the National Fuel Gas Code if the vent will have elbows or share venting with another natural draft appliance.



**Warning:** Do not combine vent with a mechanically vented appliance

#### 3.6.1 Horizontal venting



**Warning:** Horizontally venting to a vertically constructed vent stack along an outside wall of a building is not permissible



**Warning:** Horizontally venting to a sidewall vent terminator (without power vent) is not permissible

A power vent, with a proof-draft safety interlock device, is required for sidewall venting. Contact your dealer. In the Commonwealth of Massachusetts power vented applications must utilize proof of draft safety interlock device.

The following are two types of horizontal venting recommended:

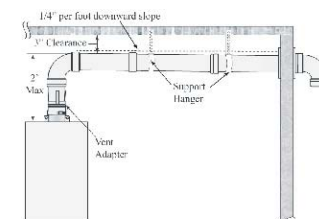

Typical Horizontal Termination w 1/4 per foot Downward slop

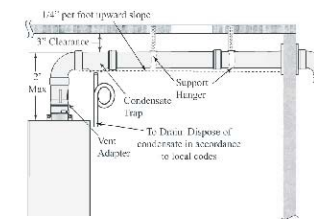

Typical Horizontal Termination w 1/4 per foot Upward slop

#### 3.6.2 Vertical venting

A properly sized gas vent constructed of double wall Type B gas vent is recommended, see "Size D" on tables 2.1 & 2.2. Under no circumstances should the vent pipe be reduced in size.

The minimum vertical gas vent height allowed is 6 feet (1.8m), horizontal vent connectors and elbows are not to be considered in the total gas vent height.

All gas vent sections must be secured to each other with sheet metal screws and be properly supported.

Horizontal runs:

Any gas vent section that is greater than 45 degrees from the vertical is considered horizontal. Horizontal section must slope upwards at least 1 inch (1.54cm) for every foot of its horizontal length and be properly supported. Keep the horizontal section short and avoid too many elbows. The maximum horizontal run allowed is half of the total vertical vent height, horizontal vent connectors and elbows are not to be considered in the total gas vent height.

Vent termination:

The gas vent constructed of double wall Type B gas vent must terminate above the roof surface with a listed vent cap at a height that is in accordance with Fig 3.6.2.1 and table 3.6.1, provided they are at least 8 feet (2.4m) from a vertical wall or similar obstruction. All other gas vents that are not able to terminate within the minimum specified height allowed must terminate not less than 2 feet (0.6m) above the highest point where it is passed through the roof and at least 2 feet (0.6m) higher than any vertical wall or similar obstruction within 10 feet (3.1m)

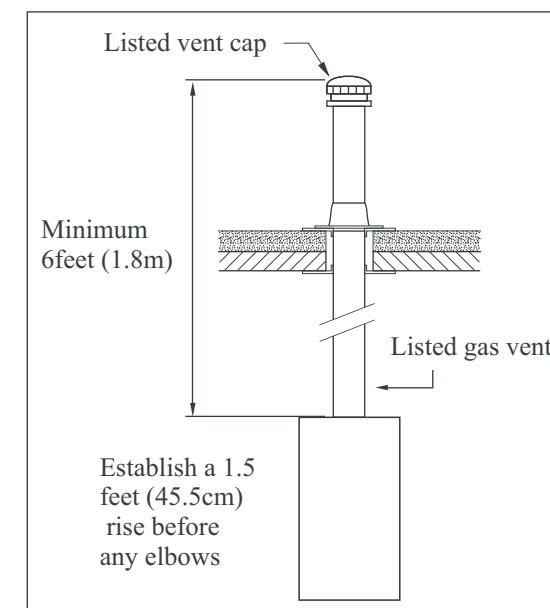

Fig. 3.6.2.1 Flat roof

#### Masonry chimney

Masonry chimney shall be built and installed in accordance with NFPA 211 or local codes. A properly sized gas vent pipe ( see "Size D" on tables 2.1 & 2.2 for the required minimum vent diameter of metal double wall Type B), or an approved clay flue liner or a listed chimney lining system must be used when venting into a naturally drafting, internal masonry chimney. Local codes may require the use of both gas vent and an approved lining system when venting into a masonry chimney. The commonwealth of Massachusetts requires the use of a listed liner. Lining systems include approved clay flue lining, a listed chimney lining system or other approved material that will resist corrosion, erosion, softening, or cracking from exhaust flue gases at temperatures up to 1800 degresss F (980 degree C). The lining system must be listed for use with naturally drafting, draft hood equipped gas appliances. Follow local codes and refer to NFGC 54 and NFPA 58.

#### Existing interior masonry chimney

The metal gas vent pipe should be permanently mounted inside the masonry chimney. Double wall Type B gas vent is recommended. The masonry chimney may have to be tile or metal lined before the insertion of gas vent pipe, check local codes for clarification. The lining material must be listed for use only with naturally drafting, draft hood equipped gas appliances. Follow manufacturers instructions for installation of listed lining materials. You may not vent any other fuel burning appliances into any free space remaining in the chimney. The minimum vertical gas vent length within the masonry chimney should be no less than 5ft (1.5m), the vent terminator should extend at least 3 feet (0.9m) above where the chimney meets the roofline and at least 2 feet (0.6m) higher than any vertical wall or similar obstruction within 10 feet (3.1m). The top of the gas vent should have an approved vent terminator, see Fig. 3.6.2.2

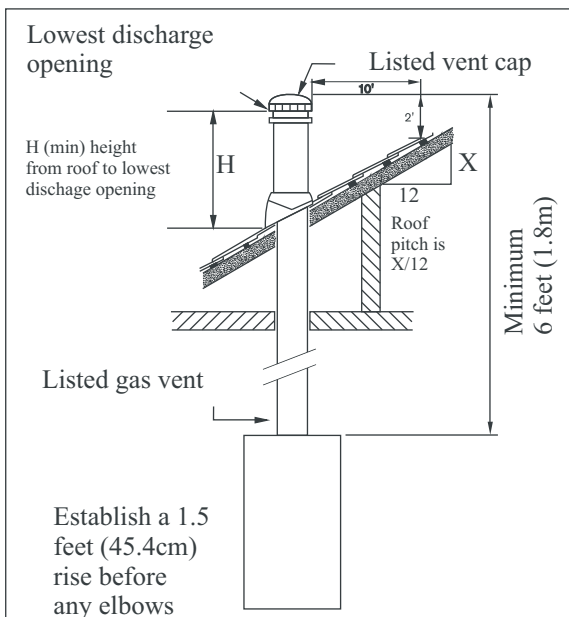

Fig. 3.6.2.2 Pitch roof

Gas vent termination for listed vent caps		
Roof pitch	H (minimum) feet	Meters
Flat to 6/12	1.0	0.30
6/12 to 7/12	1.25	0.38
Over 7/12 to 8/12	1.5	0.46
Over 8/12 to 9/12	2.0	0.61
Over 9/12 to 10/12	2.5	0.76
Over 10/12 to 11/12	3.25	0.99
Over 11/12 to 12/12	4.0	1.22
Over 12/12 to 14/12	5.0	1.52
Over 14/12 to 16/12	6.0	1.83
Over 16/12 to 18/12	7.0	2.13
Over 18/12 to 20/12	7.5	2.27
Over 20/12 to 21/12	8.0	2.44

Table 3.6.1

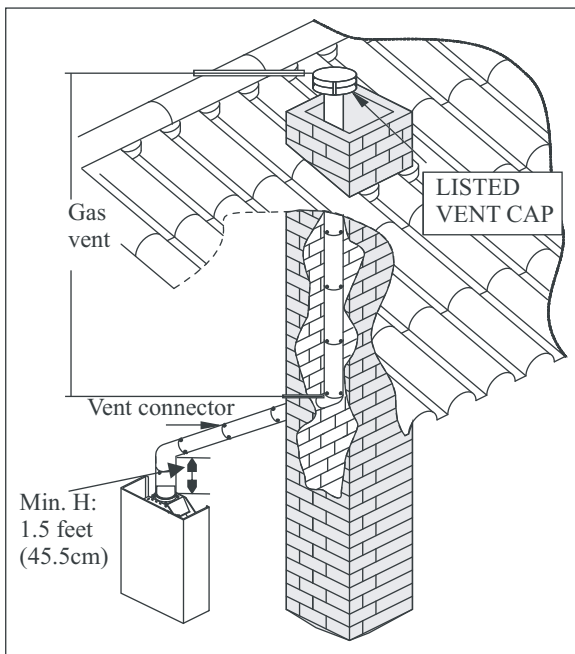

Fig 3.6.2.3 Masonry chimney

### 3.7 Gas piping & connections



Before connecting the gas supply, check the rating plate on the right side of the heater to be sure that the heater is rated for the same gas to which it will be connected.

In the United States: The installation must conform with local codes or, in the absence of local codes, the National Fuel Gas Code ANSI Z223.1/ NFPA54.

Note: The gas pressure regulator is not supplied with the gas water heater. Check with local retailers or gas suppliers for detailed information regarding the gas pressure regulator



**Warning:** DO NOT connect to an unregulated or high pressure propane line or to a high pressure commercial natural gas line



**Warning:** The heater must be isolated from the gas supply piping system during any pressure testing of that system at test pressures equal to or more than 0.5psi (3440Pa). If over pressure has occurred, such as through improper testing of the gas lines or malfunction of the supply system, the gas valve must be checked for safe operation



**Caution:** When connecting the gas pipe to the gas inlet, use TWO wrenches and DO NOT tighten the connectors too hard to avoid damaging the gas valves

#### Gas connections

- ▶ Install a manual gas shut off valve, on the supply line.
- ▶ Install a union when connecting gas supply.
- ▶ Attach a installer supplied gas pressure regulator to the inlet gas pipe. The minimum diameter required for the connector used is G1/2 inch.

Fig. 3.7.1 shows the locations of gas inlet, water inlet/outlet of most types of gas water heaters. Fig 3.7.2 shows the special configuration of 32-W, where the gas input is at the middle. The gas inlet, water inlet/outlet are identified and labeled on the unit. Please make sure that you connect the gas and water lines to the correct inlets / outlet

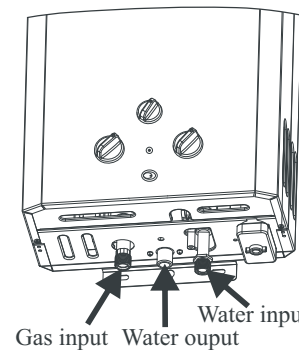

Fig 3.7.1

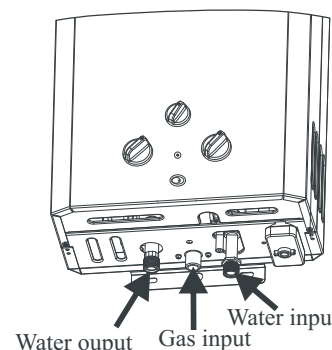

Fig 3.7.2

National Fuel Gas Code requires that a sediment trap (drip leg) be installed on gas appliances not so equipped. The drip leg must be accessible and not subject to freezing conditions. Install in accordance with the recommendations of the serving gas supplier.

When connections are made, check for gas leaks at all joints. Apply some gas leak detection solution to all gas fittings. Bubbles are a sign of a leak. Acombustible gas detector may also be used to detect for leaks.



**Danger:** if you have a leak, shut off the gas. Tighten appropriate fitting to stop leak. Turn the gas on and check again with a gas leak detection solution. Never test for gas leaks using a match or flame.

#### High altitude installation

The gas water heater is designed for low altitude use only, it is not recommended that the gas water heater be installed and used when the altitude is higher than 1960ft (600m)

#### Water connections



When facing the heater, the cold water inlet is on the bottom right and the hot water outlet is on the bottom left (See Fig.3.7.1 &3.7.2)

Install unions or the Webstone service valves when connecting plumbing to the water heater. This will facilitate any necessary cleaning and servicing.

Although water piping throughout your structure maybe other than copper, we recommend that copper piping or suitable rated stainless steel flex line piping be used for at least three feet before and after the heater (follow local codes if more stringent). Never sweat any rigid piping directly to or beneath the water connections or damage can occur to the internal water valve from heating of the pipe. Plastics or other PEX type plumbing line materials are not recommended for connecting directly to the water heater. Keep water inlet and outlet pipes to no less than 1/2 inch (12.7mm) diameter to allow the full flow capacity. It is recommended that all water piping below the heater be properly insulated to avoid heat loss. The freeze protection provided within the heater will not prevent any freeze damage to the exterior water piping. If the cold and hot connections to the heater are reversed, the heater will not function. Be certain there are no loose

particles or dirt in the piping. Blow out or flush the lines before connecting to the water heater. Full port valves should be installed on both the cold water supply and hotwater outlet lines to facilitate servicing the heater (see Fig. 3.7.3). For installation on a private well system with the use of a pressure tank, the lowest pressure range setting recommended is 30-50psi (2.07 and 3.45bar).

#### Connecting the pressure relief valve (PRV)

A installer supplied pressure relief valve must be installed at the time of installation, NO valve is to be placed between the PRV and the heater No reducing coupling or other restriction may be installed in the discharge line. The discharge line must be a minimum of 4 inches above drain and installed such that it allows complete drainage of both the PRV and the line.

The location of the PRV must be readily accessible for servicing or replacement, and be mounted as close to the water heater as possible. See Fig. 3.7.3. To install the PRV, a suitable fitting connected to an extension on a "T" fitting can be sweated to the hot water line. Support all piping.

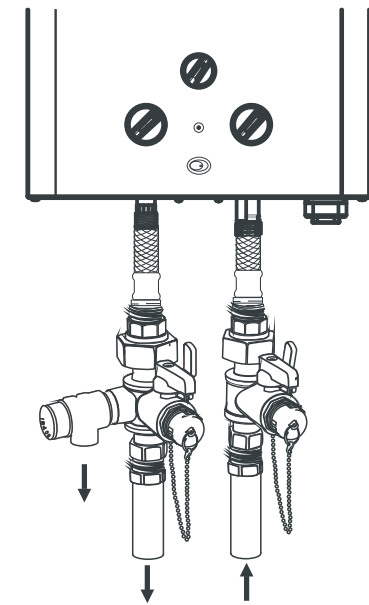

Fig.3.7.3 Plumbing connections

## 4). Operation Instructions

### 4.1 For your safety read before operating your water heater



*Warning: If you do not follow instructions exactly, a fire or explosion may result causing property damage, personal injury or loss of life*

- This appliance is equipped with pulse ignition for lighting the main burners. When turning the heater on, follow these instructions exactly.
- Before operating the unit, set the On/Off switch to the On (-) position. The On/Off switch is located on the bottom or right side of the front panel of the heater. Smell all around the appliance area for gas. Be sure to smell next to the floor because some gas is heavier than air and will settle on the floor.

#### What to do if you smell gas

Close gas valve. Open windows.

Do not try to light any appliance.

Do not touch any electric switch, do not use any phone in your building

Immediately call your gas supplier from a neighbors phone.

Follow the gas suppliers instructions.

If you cannot reach your gas supplier, call the fire department

- Use only your hand to push in the On/Off control button. Never use tools. Follow these instructions exactly. If control button is jammed, close the gas supply and call a qualified service technician. Attempted forceful repair may result in a fire or explosion.
- Do not use this appliance if any part has been under water. Immediately call a qualified service technician to inspect the appliance and to replace any part of the control system and any gas control which has been under water.

### 4.2 Lighting instructions

- STOP! Read the previous safety information.
- The gas valve must be shut off by putting the On/Off switch to position OFF (○). Wait 5 minutes to clear out any gas. If you smell gas, Stop! follow B in chapter 4.1. If you do not smell gas, go to the next step.

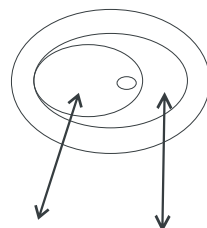

Sign of ON Sign of OFF

Fig 4.2.1 On/Off switch

- This water heater is equipped with an auto pulse ignition and control system.

- Set the On/Off switch to the On (-) position. In this position, the water heater is ready to use.

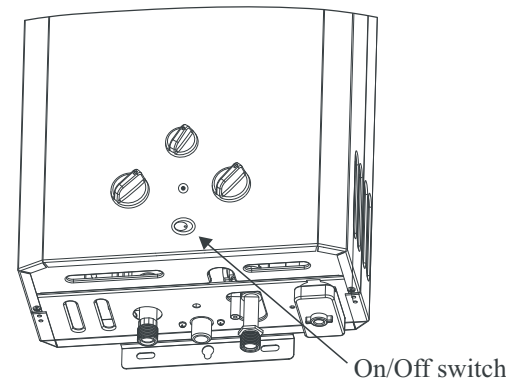

On/Off switch

- Open hot water tap to a flow rate above the minimum activation rates listed in chapter 2.1. The automatic ignition system will light the main burner in about 3 seconds. The ignition pin will be stopped within 8 seconds, try again if there is no ignition flame and burner is not lighted.
- The indicator will turn to green from red when the main burner is on. (This indicator is not equipped for every model, check your product)



*Note: On first time initial installation, existence of air in the gas supply line and in the water heater line may cause some ignition delay. In that case, repeat the ignition process until all the air has been purged.*

### 4.3 To turn off appliance

- Set the On/Off switch to the OFF (○) position
- Shut installer supplied manual gas shut off valve on the supply line to the heater

### 4.4 Setting the water temperature

The output temperature can be adjusted with either the water flow adjustment knob or the gas control knob.

#### Water flow adjustment knob

The water flow adjustment knob on the front bottom of the heater (see Fig. 4.4.1) adjusts temperature by adjusting flow capacity

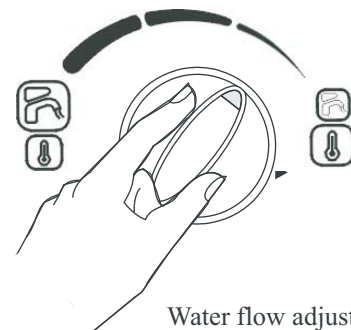

Water flow adjustment knob

Fig.4.4.1

As the water flow adjustment knob is turned counter-clockwise, the output temperature will be lower and the activation rate will be raised. Turning the knob clockwise will raise the temperature and lower the activation rate.

### 4.5 Power adjustment

Less power.  
Lower water temperature

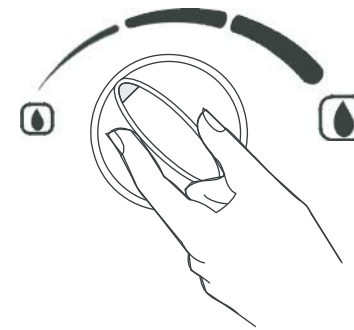

Fig 4.5.1

More power.  
Higher water temperature

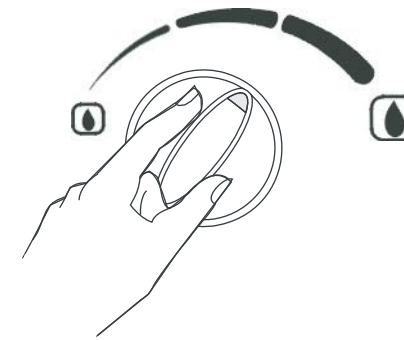
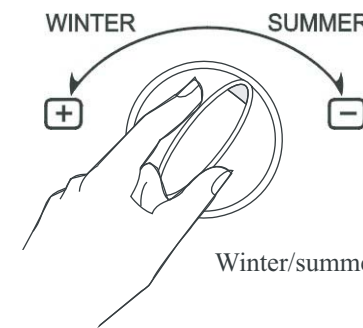

Fig 4.5.2

### 4.6 Winter/summer options

Winter/Summer switch is an energy-saving device. When the control is at the SUMMER position, half of the burners in the heater will be turned off to save energy. When the switch is at the WINTER position, the heater will have a full flame.



Winter/summer options

Fig 4.5.3

### 4.7 Purge the appliance

If there is a risk of freezing, proceed as follows: Turn the release valve pipe counter-clockwise, the remaining water will come out, emptying the appliance of all water.

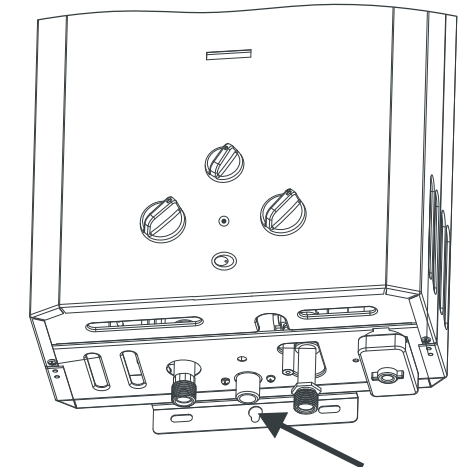

Fig. 4.7.1 Release valve

## 5). Maintenance and service

### 5.1 Maintenance intervals.



*Warning: Failure to perform recommended maintenance may result in complete failure of the unit over time. The warranty does not cover failures due to improper or insufficient maintenance*

The gas water heater requires periodic maintenance. The below time maintenance intervals should keep the unit operating for many years.

Every year

- Inspect inlet water filter screen.
- Inspect the ignition and sensor pins
- Inspect burner assembly

Inspect inlet water filter screen

Shut off the installer supplied cold water isolation valve to the heater. If one is not installed, install before proceeding. Open the nearest hot water tap to drain the plumbing lines. Position a bucket under the heaters water valve assembly to catch any water that may drain from the heater. Disconnect the water supply pipe to the water heater, remove filter located at the input end of the water valve, clean with water and inspect for damage. If the filter is at all damaged, it should be replaced.

### 5.2 Ignition and sensor pins

The ignition and sensor pins should be cleaned and without dust & rustiness. Open the front panel, check the ignition and sensor pins by view or clean them with duster cloth.

Inspecting & cleaning ignition and sensor pins

Shut off gas supply to the heater using installer supplied manual gas shut off. Open the front panel. The ignition and sensor pins are mounted in the center of the burner assembly, at the base of the pins there are three retaining clips. Release the pins from the clips. Clean them by emery cloth. Reinstall the ignition and sensor pins following removal instructions in reverse. Open gas supply and return heater to service.

### 5.3 Main burners

The main burner flames should be blue, with a more intense blue cone in the center core. Yellow flames could be a sign of wrong size gas orifices or dirty burners, a blockage on the heat exchanger fins. If some burners have yellow flames while other have blue flames, it is likely that dust, lint or spider webs have partially clogged the burner venturis. To clean the burners, contact a qualified service person.

### 5.4 Vent assembly

Inspect the draft hood and heat exchanger fins for signs of soot build-up or any other foreign material such as spider webs. Clean out any debris found in the vent hood. Signs of soot indicate insufficient combustion air or exhaust draft. Check for vent assembly blockage or combustion air blockage on the underside of the unit.

### 5.5 Mineral scale build-up

The gas water heater, when operated at lower temperature settings, does not accumulate mineral build-up. However, if the heater is used at the higher temperature settings and the water has a high mineral content, periodic descaling may be necessary. The heating coils should be flushed with a descaling solution

#### 5.5.1 Descaling heat exchanger

1. Shut off the water supply to the water heater using isolation valve.
2. Open hot water taps to drain and relieve pressure from the plumbing system.
3. Drain water from the units heat exchanger by disconnecting inlet and outlet water connections.
4. Connect the line (A) from the outlet of the installer supplied circulating pump to the inlet water fitting on the water heater
5. Using another line (B), connect to the water outlet fitting on the water heater. Route the other end of this line into a descaling reservoir.
6. Using a 3rd line (C) from the descaling reservoir, connect to the inlet side of circulating pump. Verify there is a filter on the end of the line in the descaling reservoir.
7. Make sure all connections are "hand tight".
8. Fill tank with descaling solution so lines inside are submersed. We recommend a straight white vinegar solution. If using a commercial descalant, refer to manufacturers instructions on dilution with water.
9. Operate the circulating pump
10. Make sure there are no leaks and the solution is flowing from the descaling reservoir through the heat exchanger and returning to the reservoir.

11. Run solution through the heat exchanger until the solution returning to the descaling reservoir comes out clear. (Changing to a fresh solution may be necessary during this process.)
12. Disconnect all lines and drain all solution from heat exchanger. Properly discard solution
13. Position a container below the hot water outlet and connect cold water supply. Open cold water supply isolation valve and flush heat exchanger with clean water.
14. Shut cold water isolation valve and reconnect hot water supply to the water heater.
15. Open water isolation valves, and return the unit to service.

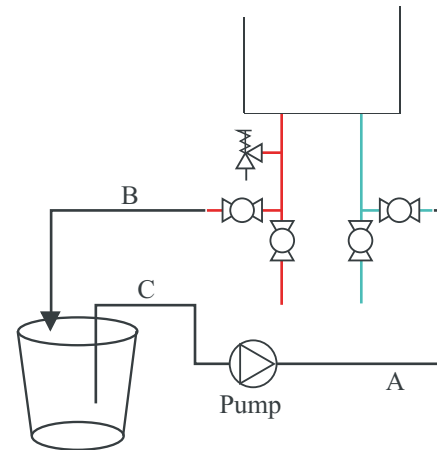

Fig .5.6.1.1

## 6. Troubleshooting

### 6.1 Introduction

Many of the questions customers ask regarding operation of this unit can be answered by following the troubleshooting steps as outlined below. For best results, perform each step before proceeding to the next. The suggested solutions may require that the cover be taken off

### 6.2 No spark at ignition pin with water flow

1. Verify the On/Off button, located at bottom or right side of the front panel of the heater, is complete depressed on the On position, see chapter 4.2, Fig. 4.2.1
2. Verify the cold water supply is connected to the right side rear of the water valve.
3. Close installer supplied cold water shut off valve (if none installed, install before proceeding). Open all hot water taps supplied by the heater. Wait 5 minutes and check all taps. Any water running is a sign of a plumbing crossover. Consult a local plumber or service person for help in correcting a plumbing crossover.
4. Confirm that there is an adequate water pressure to start the water heater. The minimum startup water pressure should be over 5psi (35kPa).
5. Inspect the water path for obstructions. Make sure all outlets (i.e. showerheads, faucet aerators and whole house filters ) are clear of debris. Inspect and clean the water heater inlet filter screen.
6. Verify all wire connections are secure, paying close attention to the wire connection between the ignition control box and ignition pin.

7. Verify the microswitch located on the bottom of gas valve is firmly mounted and wire clip connector is secure.

8. Check the battery and battery box. Change to a new set of battery if it has been used for more than 6 months. Check the metal connecting plate in the battery box, clean it if there is any dust or rustiness.

### 6.3 Spark appears when hot water is turned on, but burners will not ignite

1. Verify gas type indicated in the rating sticker located on the covers right hand side, coincides with the gas type you are using. NG is a natural gas unit and LPG is for liquid propane gas (see chapter 2.2)
2. If the unit was just installed or the gas line has been worked on, there may be air in the gas line. Bleed out the air trapped in the gas line by turning the hot water faucet on and off until the burners ignite. (Please note: depending on how much air is in the line this could take numerous cycles of turning the faucet on and off)
3. Verify gas supply is on at Natural Gas meter or Propane tank. Make sure all manual gas shut off valves are open.
4. Have a licensed gas technician confirm adequate gas pressure at the inlet tap. (See gas requirements in chapter 2.1). If gas is not present, verify the regulator you purchased is correct and in the upright position. The arrow on the back of the regulator should point in the same direction as gas flow.
5. Confirm wire connection to the ignition pin is secure. See components diagram for location. Inspect terminals for corrosion, and clean them if corrosion occurs.
6. Verify adequate voltage. Check the condition of battery and change to a new set if necessary.

### 6.4 Main burners go out during hot water use

1. Water pressure is dropping below required activation water pressure. Confirm that there is an adequate water pressure to start the water heater. The minimum startup water pressure should be over 5psi (35kPa).
2. Close installer supplied cold water shut off valve (if none installed, install before proceeding). Open all hot water taps supplied by the heater. Wait 5 minutes and check all taps. Any water running is a sign of a plumbing crossover. Consult a local plumber or service person for help correcting a plumbing crossover.
3. The minimum water pressure for the home should be 30psi or greater. For installation on a private well system with use of a pressure tank, the lowest pressure range setting recommended is 30-50psi (2.07-3.45bar )

4. Hot water is very hot out of the tap, requiring a lot of cold water to be added with it in order to attain a useable hot water temperature. The addition of too much cold water will overpower and slow the flow within the tankless heater, decreasing it below activation point, which shuts off the burners. The end result is nothing but cold water coming out of the outlet. Reduce the need for cold water mixed by turning the power adjustment knob counter-clockwise for lower hot water temperatures. See chapters 4.4 and 4.5 for details in lowering temperature. If the problem persists, call the retailer or service person for help.
5. The overheat sensor is tripped. The water heater has a thermostat at the top of heat exchanger, and the pre-set temperature is 80C ° (176F°). If the inlet water is preheated, the unit will overheat, stopping the flow of gas. Plumb inlet with cold water only.
6. Flue gas sensor is tripped. Lack of adequate combustion air or failure to vent properly by reducing pipe diameter, improper use of elbows or exceeding maximum vent length will interrupt the flue gas sensor circuit. Confirm venting and combustion air is in accordance with requirements in this installation manual
7. If the water has a high mineral content, the heat exchanger may be scaled internally. This restricts the water path, causing the water to over-heat and trip the overheat sensor shutting all gas flow. To descale the heat exchanger, see chapter 5.5.1

8. There is a built-in 20 minute timer (optional) in the water heater as a safety feature. The timer turns the heater off automatically after 20 minutes of continuous operation. Restart the water heater 5 minutes after the exhausted gas has been ventilated out.

### 6.5 Hot water temperature fluctuates at tap

1. Close installer supplied cold water shut off valve (if none installed, install before proceeding.) Open all hot water taps supplied by the heater. Wait 5 minutes and check all taps. Any water running is a sign of a plumbing crossover. Consult a local plumber or service person for help correcting a plumbing crossover.
2. Check for a clogged inlet water filter screen.
3. Hot water is very hot out of the tap, requiring a lot of cold water to be added with it in order to attain a useable hot water temperature. The addition of too much cold water will overpower and slow the flow within

the tankless heater, decreasing it below activation point, which shuts off the burner. The end result is nothing but cold water coming out of the outlet. Reduce the need for cold water mixed by turning the gas adjustment knob counterclockwise for lower hot water temperatures. See chapter 4.5. If the problem persists, call the retailer or service person for help.

4. If the water pressure in the home is erratic and the water flow is not consistent while a tap is opened, then the temperature of the hot water will fluctuate. The minimum water pressure for the home should be 30psi (2.07bar) or greater. For installations on a private well system with the use of a pressure tank, the lowest pressure range setting recommended is 30-50psi (2.07-3.45bar). The use of a pressure reducing/regulating valve before the water heater (directly after the pressure tank on well systems) is an effective way to maintain constant water pressure to the water heater.

5. If the inlet water temperature is not steady then the hot water temperature from the water heater will fluctuate.

6. The gas pressure also needs to be stable and adequate. Ensure gas pressure is in accordance with specifications in the installation manual. A gas pressure reading is needed to proceed further. Contact your original installer or a local certified gas technician to obtain this reading.

#### 6.6 Water is too hot

1. Verify gas type indicated in the rating sticker located on the cover's right hand side coincides with the gas type you are using. NG is a Natural Gas unit and LPG is for Liquid Propane (see chapter 2.2)
2. Adjust the power adjustment knob counterclockwise for cooler temperatures. If the water is still too hot, the temperature (water flow) adjustment knob maybe set too high. Lower the setting and test the water temperature. This dial turns counterclockwise for lower temperatures and clockwise for higher temperatures.
3. Inlet water is preheated. The gas water heater is designed for cold water feed only. Replumb the heater with cold water to the inlet.
4. Increase flow rate. Restrictions in the water path can slow the flow of water through the heater, resulting in very hot outlet temperatures. Restrictive showerheads and faucet aerators should be cleaned out or upgraded with less restrictive ones. In addition, the inlet filter on the water heater should be cleaned and inspected.
5. If water is still too hot, call the retailer or service agent for help.
6. If the water has a high mineral content, the heat exchanger may be scaled internally. This restricts the water path, causing the water to boil and produce extremely hot temperatures. To descale the heat exchanger, see chapter 5.5.1

#### 6.7 Water is not hot enough

1. Verify gas type indicated in the rating sticker located on the cover's right hand side coincides with the gas type you are using. NG is a natural gas unit and LPG is for liquid propane (see chapter 2.2).
2. Flow at one particular tap is too great or too many fixtures are running at one time. Lower flow to stay within heater's specifications.
3. Ensure the power adjustment knob is all the way clockwise to highest temperatures. In addition, the water flow adjustment knob maybe set too low. Raise the setting and test the water temperature. This dial turns counterclockwise for lower temperatures and clockwise for higher temperatures.
4. Close installer supplied cold water shut off valve (if none installed, install before proceeding). Open all hot water taps supplied by the heater. Wait 5 minutes and check all taps. Any water running is a sign of a plumbing crossover. Consult a local plumber or service person for help correcting a plumbing crossover.
5. Inspect the water path outside the heater for obstructions. Make sure all outlets (i.e. showerheads, faucet aerators and whole house filters) are clear of debris. Also, the water heater's inlet filter should be inspected and cleaned.
6. Gas pressure is too low. Ensure gas pressure is in accordance with specifications in the installation manual. Contact your original installer or a local certified gas technician to obtain this reading.

#### 6.8 Low hot water pressure

1. Confirm that there is an adequate water pressure to start the water heater. The minimum startup water pressure should be over 5psi (35kPa).
2. Inspect the water path outside the heater for obstructions. Make sure all outlets (i.e. showerheads, faucet aerators and whole house filters) are clear of debris.
3. Be sure to run only one major fixture at a time with this water heater. Opening too many taps at one time can disperse water flow resulting in diminished flow pressure at all outlets.
4. If the water has a high mineral content, the heat exchanger may be scaled internally. This restricts the water path, causing diminished water flow. To descale the heat exchanger, see chapter 5.5.1

#### 6.9 Noise when heater is running

1. Confirm that there is an adequate water pressure to start the water heater. The minimum startup water pressure should be over 5psi (35kPa).
2. Inspect the water path outside the heater for obstructions. Make sure all outlets (i.e. showerheads, faucet aerators and whole house filters) are clear of debris. Restrictions in the water path can slow water flow through the heat exchanger causing it to boil and make noise.
3. If the water has a high mineral content, the heat exchanger may be scaled internally. This restricts the water path, causing the water to boil resulting in noise and overheating.

#### 6.10 Burners do not burn cleanly, yellow flames when operating

1. Verify gas type indicated in the rating sticker located on the heater's right side coincides with the gas type you are using. NG is a natural gas unit and LPG is for liquid propane.
2. Gas pressure may be inadequate resulting in improper combustion. Ensure gas pressure is in accordance with specifications in the installation manual. A gas pressure reading is needed to proceed further. Contact your original installer or a local certified gas technician to obtain this reading.
3. Ventilation is not adequate. Ensure adequate combustion air is being supplied to the unit in accordance with requirements in the installation manual.
4. Verify the water heater is vented properly. Ensure the venting is in accordance with requirements in the installation manual.
5. The water heater has burners much like a furnace. It is essential that they remain clean and are supplied with adequate air for combustion. If the flames burn yellow or orange, it is strongly recommended that the burners be removed, the fins on the top of the heat exchanger can be accessed and brushed or vacuumed clean.

#### Protecting the environment



##### Packing

The packing box may be fully recycled as confirmed by the recycling symbol 

##### Components

Many parts in the heater can be fully recycled in the end of the product life. Contact your city authorities for information about the disposal of recyclable products.

##### Saving water resources:

Make sure you close all taps after any use. Avoid leaving the taps dripping. Repair any leaking tap. Define the temperature you want. This way you have the precise water flow needed (mixing cold water to regulate temperature will increase the water flow with consequent waste of water)

For increased safety shut off the appliance from the main water supply if you are staying away from home for a considerable time.

At below freezing temperatures, disconnect the plumbing connections to the heater and allow the heater to drain.

To prevent any freeze damage, introduce short bursts of compressed air (20-40 psi/ 1.38-2.76bar) through these connections to remove the residual water in the horizontal pipes and water valve.

Follow instructions in chapter 4.7 to remove any additional water remaining in the water valve and heat exchanger



## 8). Interior components and diagram parts list

### 8.1 Interior components

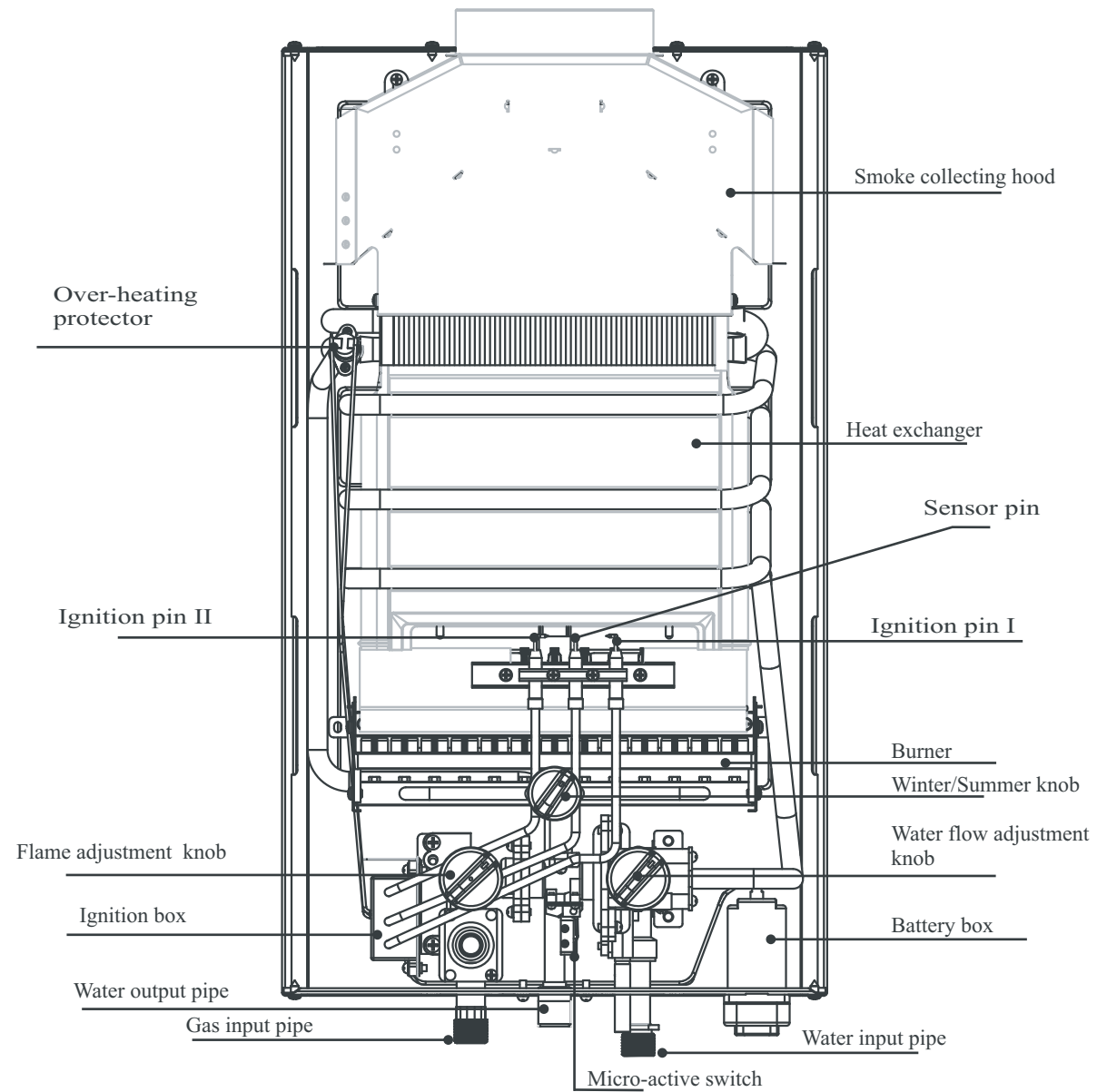

### 8.2 Components diagram

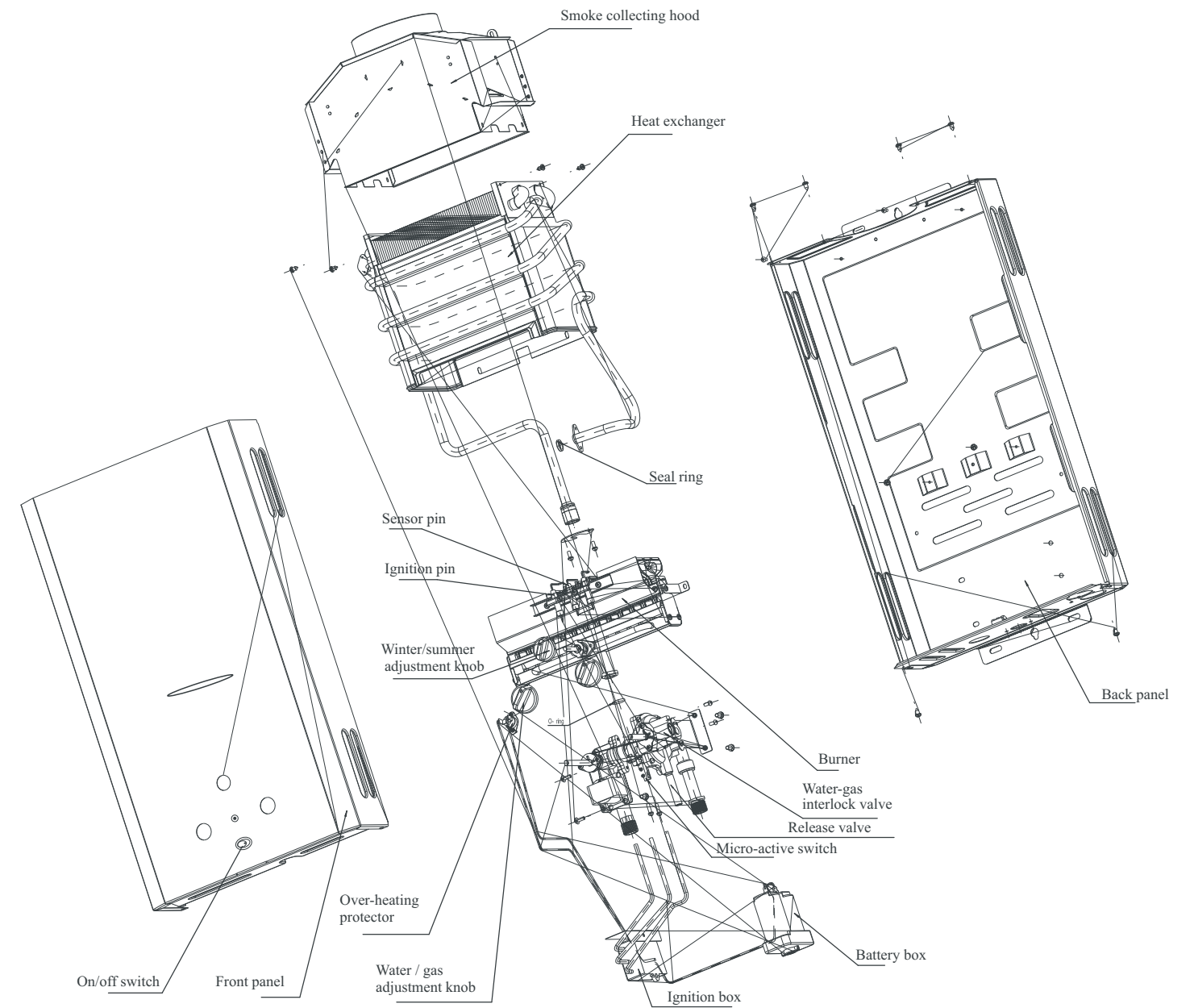

**8.3 Parts list**

Code	Name	Quantity
1	Smoke collecting hood	1
2	Back panel	1
3	Heat exchanger	1
4	Over-heating protector	1
5	Burner	1
6	Ignition pin	2
7	Water-gas interlock valve	1
8	Micro-active switch	1
9	O-ring	1
10	Seal ring	1
11	Pulse generator	1
12	On/ off switch	1
13	Battery box	1
14	Front panel	1
15	Water/gas regulator knob	2
16	Winter/summer regulator knob	1

**9. Warranty**

**The Heat Exchanger**

If the heat exchanger fails within one (1) year after the original installation and operation, the manufacturer will furnish a replacement heat exchanger.

**Exceptions**

This warranty will not apply:

1. To defects or malfunctions resulting from failure to properly install, operate or maintain the unit in accordance with the printed instructions provided.
2. To damage or abuse, accident, neglect or freezing and other acts of nature.
3. To damage resulting from operation with either the flame sensor rod or overheat sensor removed.
4. To failure of the heat exchanger resulting from the operation of the water heater in a corrosive atmosphere or at water temperatures exceeding the maximum rating, or if the water heater is not supplied with portable water.
5. To defects or damage cause by any attachment or modification, including any energy-saving device.

**All Other Parts**

If any other part fails within one (1) year after original installation and operation, the manufacturer or retailer will furnish a replacement part free of charge.

**Shipping Costs**

Any parts or product claimed to be defective must be shipped freight prepaid to the manufacturer or retailer and the repaired or replaced product or parts will be returned to the sender freight at customer's expense.

**Service Labor Costs**

This warranty does not cover any labor costs associated with services, removal or re-installation of part(s). All such costs must be borne by the Purchaser. Additionally, this warranty does not cover any labor costs associated with services, removal or re-installation of the original water heater or a replaced water heater.



Note: the water heater must be free of damaging scale deposits and not subject to gas pressures greater than those shown on the rating plate, which must not be altered, defaced or removed.

**How to make a claim**

Any claim for warranty parts should be made to your local dealer, distributor or manufacturer

In most cases, the dealer or distributor will be able to promptly honor your claim. However, all replacements are made subject to validation by dealer or distributor of in-warranty coverage. The damaged or defective item must be made available in exchange for the replacement.

**Miscellaneous**

No one is authorized to make any other warranties on behalf of the manufacturer. It is expressly understood that the replacement warranty of manufacturer shall be in lieu of any and all other warranties, express or implied, including warranties of merchantability or fitness for a particular use or purchase, and further that the manufacturer shall not be liable for any loss or damage directly or indirectly arising from the use of the hot water heater, or for any consequential damages arising from such use (including damages from water leakage). The manufacturers sole liability with respect to any defect shall be for the replacement of the defective part(s). Some states do not allow such limitations and exclusions, so the above may not apply to you.