



(Fan with Humidity Sensor - 80 CFM)

	Full Speed:	Low Speed:		
	80 CFM/0.8 Sones @ 0.1 SP, 9.7 Watts 68 CFM/1.2 Sones @ 0.25 SP, 11.8 Watts	50 CFM/<0.3 Sones @ 0.1 SP, 4.0 Watts 37 CFM/1.0 Sone @ 0.25 SP, 6.0 Watts		

Description

Low noise ceiling/wall mount ventilating fan with humidity sensor rated for continuous running. Fan has been awarded ENERGY STAR® Most Efficient in 2015. It is HVI, UL, and cUL certified, and can be used to comply with ASHRAE 62.2 (local and whole building continuously and intermittent operation), CA Title 24, and CALGreen requirements.

DC Motor/Blower

- Power rating of 120 volts/60Hz
- DC Brushless motor engineered to run continuously
- Motor equipped with thermal cutoff fuse
- Removable with permanently lubricated plug-in motor
- Allows fan to operate in full speed mode or humidity control mode by manual switch
- For humidity control mode, when humidity is above the user-adjustable set-point, fan runs at full speed (80 CFM). When humidity is below the set-point, the fan runs continuously at a pre-set lower level (0 or 50 CFM)
- Built-in soft start function to increase bearings' life
- Automatically powers OFF when impeller is locked abnormally
- Self-compensating motor speed for intended airflow when static pressure is encountered

Housing

- Galvanized steel body
- Detachable 4" diameter metal duct adapter
- Built-in backdraft damper
- Easy installation

Grille

- Attractive design using ABS material
- Attaches directly to housing with torsion springs

LED Indicator

- Blue and amber LED indicator lights to show humidity sensor and full speed modes

Warranty

- 3-year limited warranty

TYPICAL SPECIFICATION

Ventilation fan shall be Delta Breez model GBR80H; ENERGY STAR qualified with DC brushless motor engineered to run continuously for a minimum 70,000 hours; airflow rating of 80 CFM and loudness rating of 0.8 Sones at 0.1 static pressure as certified by the Home Ventilating Institute (HVI); power consumption of 9.7 Watts with efficiency rating of 8.2 CFM/Watt at 0.1" static pressure; fan will feature LED indicator running light, motor lock protection and self-compensating motor speed for intended airflow when static pressure is encountered. UL and cUL listed for tub/shower enclosure when used with GFCI-protected branch circuit wiring.

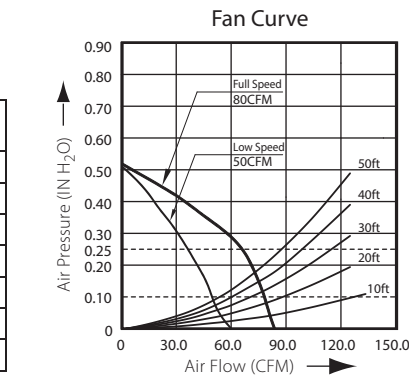
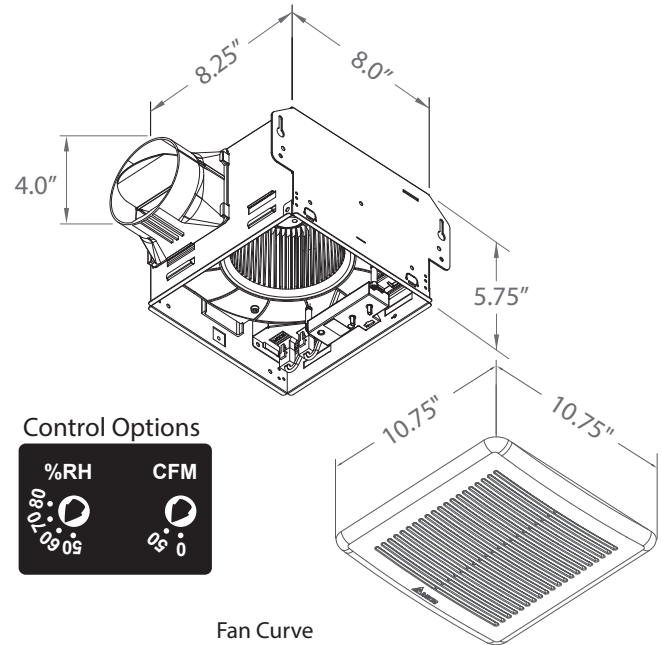

GreenBuilder GBR80H	Continuous low speed		Full speed	
	0.1	0.25	0.1	0.25
Static Pressure (inches w.g.)	0.1	0.25	0.1	0.25
Air Flow (CFM)	50	37	80	68
Sones	<0.3	1.0	0.8	1.2
Power Consumption (Watts)	4.0	6.0	9.7	11.8
Energy Efficiency (CFM/Watt)	12.5	6.1	8.2	5.7
Current (Amps)	0.22 Max			
Power Rating (V/Hz)	120 / 60			

Model	Quantity	Comments	Project:
			Location:
			Architect:
			Engineer:
			Contractor:
			Submitted by:
			Date: