

## Installation, Operation, and Maintenance Manual

### Product Preservers® Anti-Scale System Chemical-Free, Salt-Free Scale Prevention

#### Introduction

The Product Preservers® Anti-Scale System will condition the tap water providing optimum water characteristics for many applications. The result is reduced equipment maintenance requirements, longer equipment life and improved quality & consistency of your products.

The Product Preservers® system is built with the finest and most advanced materials and each system is quality inspected and pressure tested prior to shipment. With proper installation and routine maintenance, you will have years of trouble-free operation.

Please refer to this manual when performing routine filter changes. The instructions make periodic maintenance quick and easy and ensure you will receive maximum benefit from your system.

#### System Specifications

Model	SM1.0L	LG1.5L
Peak Flow Rate	6 gpm (23 lpm)	10 gpm (38 lpm)
Service Flow Rate	0.25 - 4 gpm (1 - 15 lpm)	0.5 - 10 gpm (1.9 - 38 lpm)
Gallon Rating for Cartridge	Up to 4 gpm, 24/7/365 for 2 years	Up to 6 gpm, 24/7/365 for 2 years
Maximum Pressure	90 psi (6.2 bar)	
Temperature	35°F - 100°F (2°C - 38°C)	
Inlet/Outlet Connections	¾" FNPT	
Water pH	6.5 to 8.5	
Hardness (max)	75 grains (1300 ppm CaCO <sub>3</sub> )	
Chlorine	< 3 ppm	
Iron (max)	0.3 mg/l	
Manganese (max)	0.05 mg/l	
Copper	none allowed	
Oil & H <sub>2</sub> S	none allowed	
Polyphosphate	none allowed	
Silica (max)	10 ppm	



**Capacity:** The Product Preservers® cartridge does not have a grain removal capacity, however, other contaminants present in the water will gradually degrade the effectiveness of this cartridge. Change the system cartridge at least once every two years.

## Notice to Installer

- Do not discard this manual after installation. This manual contains important operation, maintenance and precautionary information. Please present this manual to user/operator/owner after installation.
- It is strongly encouraged that you read this manual before installing the system to ensure the best possible installation.
- Installation must conform to all local and state plumbing codes and regulations.
- Connect system to cold water supply only. Water temperature cannot exceed 100°F/38°C.



- System **must be** installed in a vertical, upright and level position.
- Product Preservers® systems **must not** be used in conjunction with polyphosphate or any other scale inhibitor.
- Do not use with water that is microbiologically unsafe or of unknown quality without adequate disinfection before or after the system.
- Notice to user/operator/owner: Please retain this manual for future reference for parts, maintenance or troubleshooting.
- It is recommended that all personnel responsible for operation and maintenance of this product read the precautions, operation and maintenance sections of this manual.
- Use caution when installing **NEW COPPER LINES** immediately before the Product Preservers® system. Dissolved copper oxide from the new pipes can foul the Product Preservers® media and the equipment will not be protected.

Any system using new copper lines should be run for **4 WEEKS WITHOUT CARTRIDGE INSTALLED** to allow lines to passivate.

## Installation

1. Turn off all equipment to be fed by the Product Preservers® system, locate water supply shutoff valve and turn OFF.
2. Determine if the water line has an existing water treatment system. If so, examine system for use of polyphosphate or other scale inhibitors. Product Preservers® will not be effective if used in conjunction with other scale inhibitors. Remove the scale inhibitors from the water line or discontinue installation.
3. Install a 3/4" full-flow ball valve on the water supply side that will feed the water system.
4. Anchor the Product Preservers® system on a wall stud or suitable mounting material spanning wall studs. System must be vertical and upright.
5. Run a suitable line from the 3/4" full-flow ball valve at the tap water source to the inlet ball valve on the left side of the Product Preservers® system. Use 2-3 wraps of Teflon® tape and brace the inlet ball valve on the system with a wrench when connecting the feed water line. **NOTE: DO NOT OVERTIGHTEN CONNECTION FITTING INTO BALL VALVE.**
6. Select the appropriate size tubing for the equipment being fed and connect it to the outlet of the Product Preservers® system. **NOTE: DO NOT** connect the tubing to the equipment at this time. Prior to making connection to the equipment, this line will be used to facilitate flushing the system. As an option, a drain valve in a tee on the outlet side of the Product Preservers® system could be provided in the line to facilitate flushing when changing filters.
7. If using new copper lines to install the Product Preservers® system, install, leak test, and run the unit for **4 weeks without cartridge installed** to allow lines to passivate. Copper oxide from new pipes can foul the Product Preservers® media and leave the system unprotected.
8. With Product Preservers® inlet valve closed, slowly open the 3/4" full-flow ball valve at the tap water source. Check for leaks.
9. If a drain valve was not installed on the outlet side of the system, hold the tubing that will connect to equipment in a clean bucket or over sink or drain. Open the system inlet feed valve and allow water to flush through system for 2 minutes at the specified system flow rate to allow air bubbles to escape. **NOTE: NO ACTIVATION IS REQUIRED FOR THE Product Preservers® SYSTEM TO PERFORM PROPERLY. FLUSHING IS RECOMMENDED TO ALLOW AIR TO ESCAPE THE SYSTEM.**
10. Make certain that the end of the tubing to be connected to the equipment is clean and sanitary.
11. Connect tubing to equipment. Open all water supply valves and check for leaks.
12. If no leaks, turn on equipment and check for normal operation.
13. Attach the Service Log to the installed Product Preservers® system and fill in install date.



## Installation Precautions!

- Do **NOT** install system on line pressure above 90psi.
- Do **NOT** install system on HOT water line. Failure to limit line temperature to 100°F may result in housing failure and damage.
- Do **NOT** install the system backwards with the feed water line connected to the outlet.
- Do **NOT** use liquid pipe compounds for fitting connections. USE two to three wraps of Teflon® tape.
- Do **NOT** solder plumbing connections attached to filter housing or inlet valve. Inlet valve and filter housing will be damaged by high temperature.
- Do **NOT** allow system to freeze. Turn off water supply to housing and drain housing if temperature falls below 32°F.
- Do **NOT** install system in direct sunlight or where system is exposed to harsh chemicals or may be subjected to being struck by moving equipment, carts, mops or any other item that may cause damage.
- **ALLOW** a minimum of 3" under the housing to allow for filter replacement.
- **IF** water hammer is evident, install water hammer arrestors before the Product Preservers® unit.
- Do **NOT** overtighten fitting connections into inlet valve or housing outlet.
- Always back-up valves and fittings with a wrench when installing a fitting to avoid turning the valve.
- Do **NOT** install the unit behind equipment where it may be difficult to access the system for filter replacement.

Position the Product Preservers® unit in a suitable location. The direction of flow through the Product Preservers® unit is always through the inlet first; keep this in mind when determining installation location. Do NOT mount the Product Preservers® system near any source of heat. Also, do not mount the system above any device or area that would be adversely effected by water.

Teflon® is a registered trademark of E.I. DuPont de Nemours & Company.

## Basic Installation (and Multiple Units)

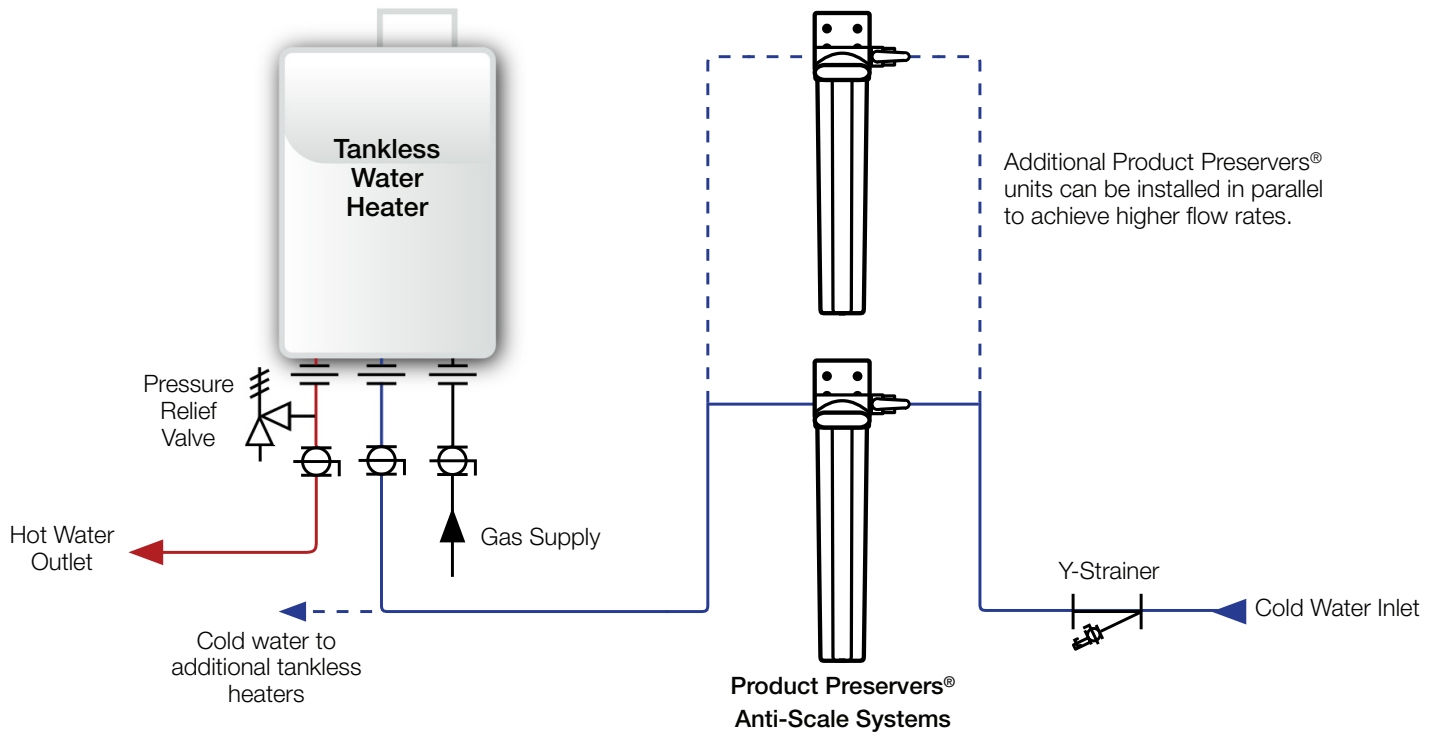

## Installation in a Recirculation System

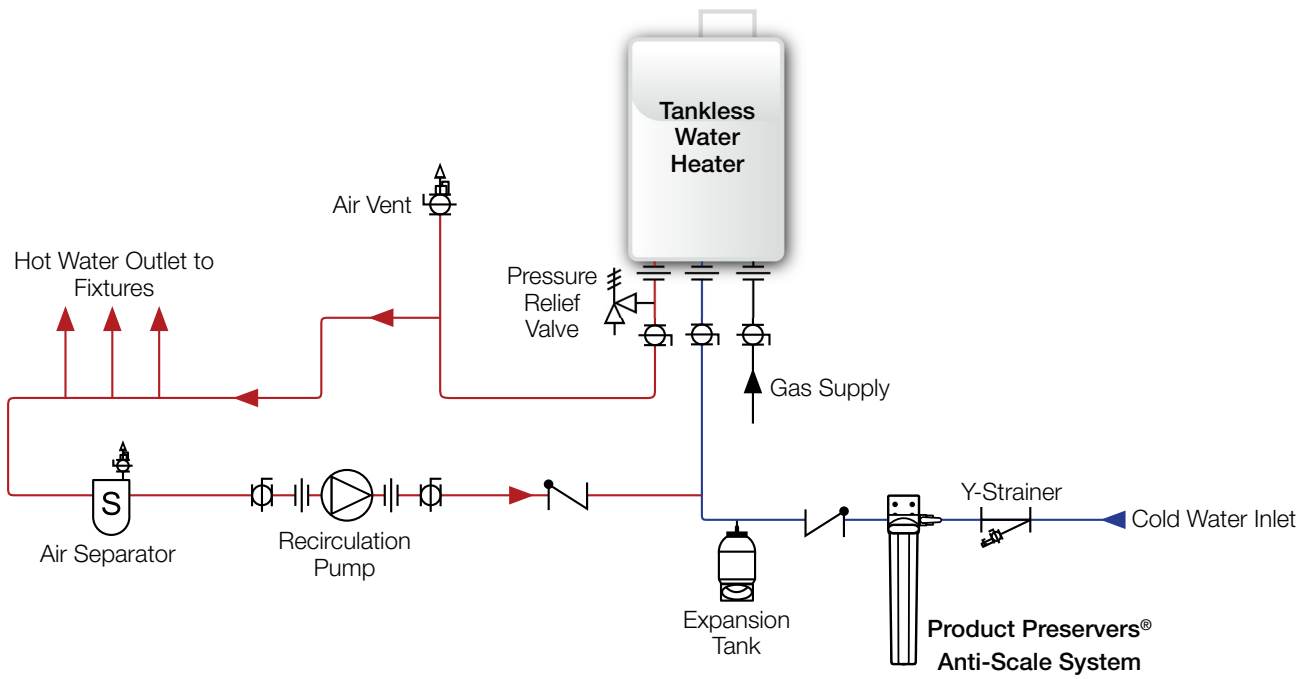

# Dimensions

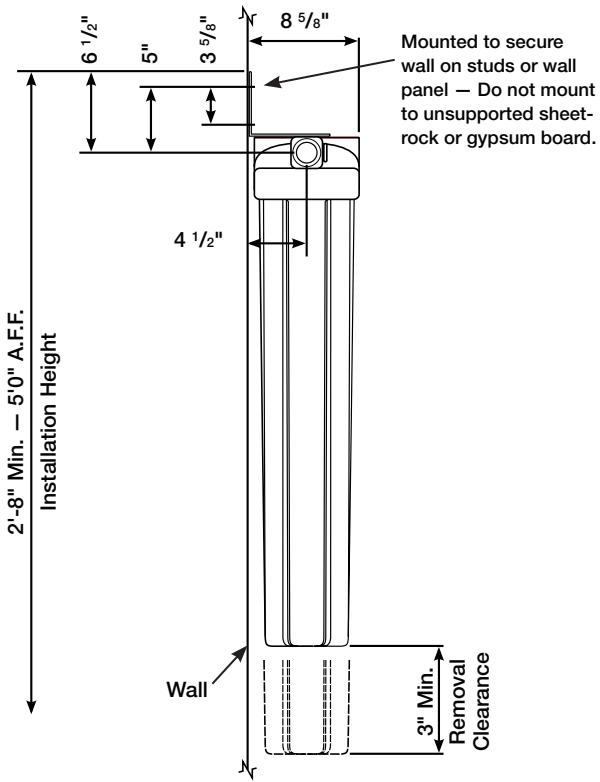

Max Pressure: 90psi (6.2 bar)  
 Max Temperature: 100°F (38°C)

Water treatment unit must be installed on the cold water supply only.

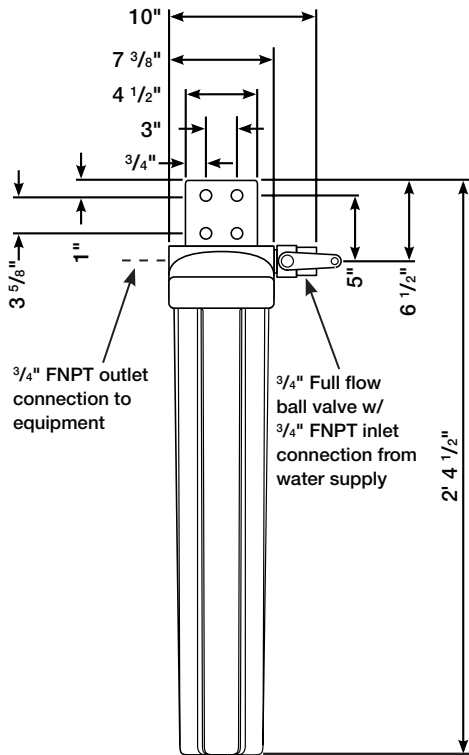

Model	Sump Color	Weight
SM1.0L	Blue	15 lbs (6.8 kg)
LG1.5L	White	19 lbs (8.6 kg)

**\*Note: Both models have same external dimensions.**

# Operation

With sufficient pressure, operation of the Product Preservers® system is completely automatic. Dependable operation involves only periodic filter changes and service documentation.

# Maintenance

Routine maintenance of your Product Preservers® system involves periodic filter cartridge changes and/or replacement of sump O-rings.

## Filter Change Frequency

If the system sizing recommendations have been followed, the Product Preservers® cartridge should last two years. Replace filter every 24 months to ensure proper operation.

## Replacement Filter Cartridges

Product Preservers® systems can only be used with Product Preservers® filter cartridges. Use of replacement cartridges other than those specified will void warranties, certifications and may compromise equipment protection, water quality and equipment life.

Model	Sump Color	Replacement Filter	Part Number
SM1.0L	Blue	SM1.0L-RM	9008878005
LG1.5L	White	LG1.5L-RM	9008876005

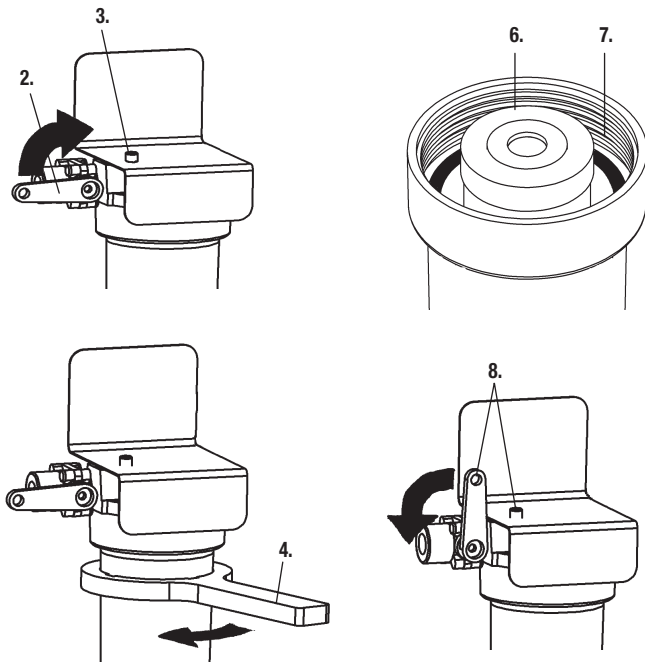

## Filter Cartridge Replacement Procedure

**IMPORTANT:** Determine whether all equipment connected to the Product Preservers® system must be turned off prior to shutting off water supply from filters.

1. If required, turn off equipment.
2. Turn OFF water to Product Preservers® system by closing inlet ball valve.
3. Press the red button to release pressure.
4. Remove housing(s) - use filter wrench if necessary.
5. Clean inside of housing sumps with warm water. If desired, disinfect housing using a teaspoon of household bleach. Add to filter bowl and add water. Let stand 5 minutes and discard.
6. Insert new cartridge into filter housing. Match cartridge model number to model number on bracket.
7. Make certain the O-ring is properly positioned and reinstall filter housing (hand tighten only). Check O-ring for damage and replace if damaged or distorted.
8. Slightly open the inlet ball valve; push the red pressure relief button to release trapped air until a small amount of water comes out - release the red button and fully open the ball valve.
9. Open the flush valve downline from the filter housing (if equipped) and flush the new cartridge to drain or bucket for two (2) minutes or until water runs clear. If no flush valve is present, disconnect line from equipment to flush to drain.
10. **VERY IMPORTANT:** With water supply inlet valve OPEN and water flow confirmed, turn on connected equipment. Failure to supply water to equipment may cause serious damage.
11. Record filter change on the service log.

# Replacement Parts for Product Preservers® Anti-Scale System

Drawing ID #	Description
1	Housing, w/PR
1a	O-Ring
2	Valve, 3/4" FxM Ball
3	Bracket, Single Housing
4	Screw
5	Pressure Relief Button
6	<b>Replacement Filter Cartridge</b>
	SM1.0L-RM - P/N 9008878005
	LG1.5L-RM - P/N 9008876005

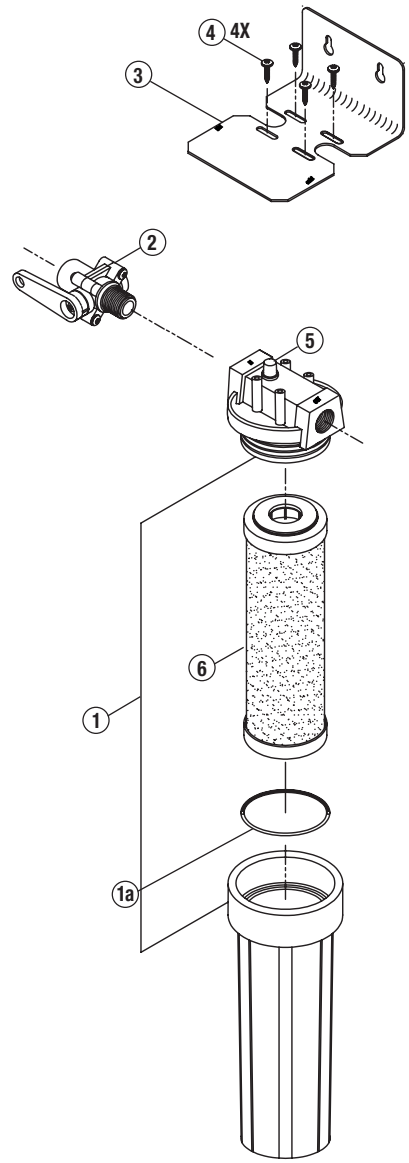

## Limited Warranty

Company warrants its Product Preservers® Anti-Scale System as follows:

- The Product Preservers® cartridge system is warranted to be free of defects in materials and workmanship for 1 year from the date of original shipment.
- Product Preservers® filter cartridges are warranted for performance for a period of one year from the date of original installation when installed and operated in accordance with the instructions in the corresponding Installation and Operation Manual.

## Conditions

1. The Product Preservers® system must be installed in applications with municipally supplied water adhering to EPA guidelines.
2. Any component failure must not result from abuse, fire, freezing or other acts of nature, violence, or improper installation.
3. Equipment must be installed and operated in compliance with the local plumbing codes and on an approved water supply.
4. Equipment is limited to use at water pressures and temperatures that do not exceed our published specifications.
5. Water supply must not exceed 2.0 PPM chlorine. For water supply exceeding 2.0 PPM chlorine, pretreatment is required. (Please contact your water treatment specialist.)
6. Information, including model number, serial number, and date of installation, must be provided for any claims pertaining to equipment in warranty.
7. Defective parts are subject to inspection by the company or any authorized representative before final commitment of warranty adjustment is made.
8. The company reserves the right to make changes or substitutions in parts or equipment with material of equal quality or value and of then current production.

## Limitations

Our obligation under this warranty with respect to the tank or valve is limited to furnishing a replacement for, or at our option, repairing any part or parts to our satisfaction that prove defective within the warranty period stated above. Such replacement parts will be delivered to the owner F.O.B. nearest factory, at no cost, excluding freight and local labor charges, if any.

Our obligation under this warranty with respect to the Product Preservers® media will be limited to furnishing a replacement for the media within two years from date of original installation. Such replacement media will be delivered to the owner F.O.B. nearest factory, at no cost, excluding freight and local labor charges, if any. Damage to the media due to chlorine, other oxidizers or fouling caused by local water conditions or any other operation outside of the limits shown under Specifications, is not covered by this warranty.

THE WARRANTY SET FORTH HEREIN IS GIVEN EXPRESSLY AND IS THE ONLY WARRANTY GIVEN BY A. O. SMITH WATER HEATERS WITH RESPECT TO THE PRODUCT. A. O. SMITH WATER HEATERS MAKES NO OTHER WARRANTIES, EXPRESS OR IMPLIED. A. O. SMITH WATER HEATERS HEREBY SPECIFICALLY DISCLAIMS ALL OTHER WARRANTIES, EXPRESS OR IMPLIED, INCLUDING BUT NOT LIMITED TO THE IMPLIED WARRANTIES OF MERCHANTABILITY AND FITNESS FOR A PARTICULAR PURPOSE.

The remedy described under this warranty shall constitute the sole and exclusive remedy for breach of warranty, and the company shall not be responsible for any incidental, special or consequential damages, including without limitation, freight, handling, lost profits or the cost of repairing or replacing other property which is damaged if this product does not work properly, other costs resulting from labor charges, delays, vandalism, negligence, fouling caused by foreign material, damage from adverse water conditions, chemical, or any other circumstances over which the company has no control. This warranty shall be invalidated by any abuse, misuse, misapplication or improper installation of the product.

Some states do not allow limitations on how long an implied warranty lasts, and some states do not allow the exclusion or limitation of incidental or consequential damages. Therefore the above limitations may not apply to you. This warranty gives you specific legal rights, and you may have other rights that vary from state to state. You should consult applicable state laws to determine your rights. SO FAR AS IS CONSISTENT WITH APPLICABLE STATE LAW, ANY IMPLIED WARRANTIES THAT MAY NOT BE DISCLAIMED, INCLUDING THE IMPLIED WARRANTIES OF MERCHANTABILITY AND FITNESS FOR A PARTICULAR PURPOSE, ARE LIMITED IN DURATION TO THE APPLICABLE WARRANTY PERIODS STATED ABOVE.



### CALIFORNIA PROPOSITION 65 WARNING

**WARNING:** This product contains chemicals known to the State of California to cause cancer and birth defects or other reproductive harm.

(California law requires this warning to be given to customers in the State of California)